

SolidPLANT Getting Started

# SolidPlant

Comprehensive Plant Design for SolidWorks



**Route it your way!**

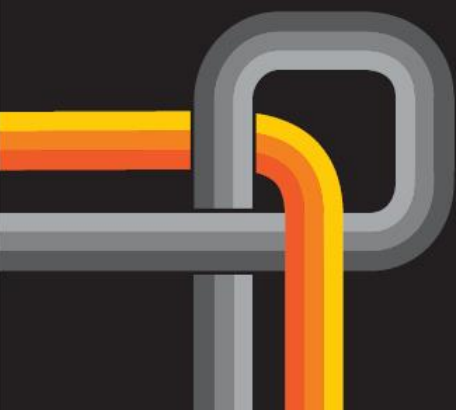

## Table of contents

<b>Introduction</b> .....	4
<b>Launching</b> .....	4
<b>SolidPlant Project Manager</b> .....	5
<b>Creating a new project</b> .....	6
<b>Open project</b> .....	7
<b>User interface</b> .....	9
<b>Application tabs</b> .....	9
<b>SolidPlant tab</b> .....	9
<b>Structure tab</b> .....	9
<b>Equipment tab</b> .....	10
<b>Routing tab</b> .....	10
<b>Component tab</b> .....	10
<b>SP Drawing tab</b> .....	10
<b>Task panes</b> .....	10
<b>SolidPlant Project Manager task pane</b> .....	11
<b>SolidPlant Pipe Routing task pane</b> .....	11
<b>Creating structures</b> .....	12
<b>Structure 3D Grid command</b> .....	12
<b>Insert Structure Member command</b> .....	16
<b>Structure modelers</b> .....	19
<b>Stair command</b> .....	19
<b>Create equipment</b> .....	22
<b>Pump equipment</b> .....	22



<b>Vessel equipment</b> .....	28
<b>Routing</b> .....	34
<b>Create a pipe line</b> .....	34
<b>Manual Route method</b> .....	35
<b>Auto Route method</b> .....	44
<b>Adding components</b> .....	48
<b>Valve component</b> .....	48
<b>Pipe Support component</b> .....	52
<b>Drawings</b> .....	55
<b>Gen PCF command</b> .....	55
<b>New Drawing command</b> .....	57
<b>BOM command</b> .....	59



# Introduction

The purpose of this document is to teach new users the fundamentals of SolidPlant3D and assist them with the main features.

SolidPlant 3D is an add-in on top of SOLIDWORKS standard edition which allows the designers to quickly create intelligent 3D process plant designs driven by specifications, and deliver easily de facto standard isometric drawings (which is Isogen®, the Alias solution embedded in SolidPlant 3D).

SolidPlant 3D is a database driven system and provides an application called SpecCreator for the generation of the piping specifications, with a wide range of catalogues to build up the needed piping components for the project.

## Launching

Solidplant 3D can be launched in three different ways.

- From the desktop shortcut.



- From **Windows Start, Programs, SolidPlant 2016, SolidPlant.**

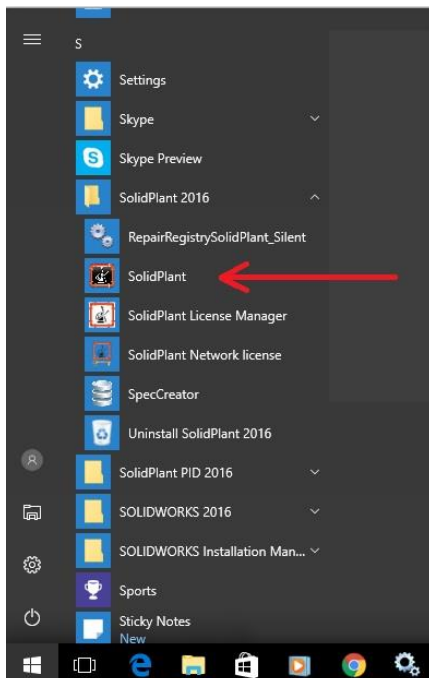

- From **SolidWorks, Tools, Add-ins**, select the **Active Add-ins** check box **SolidPlant**.

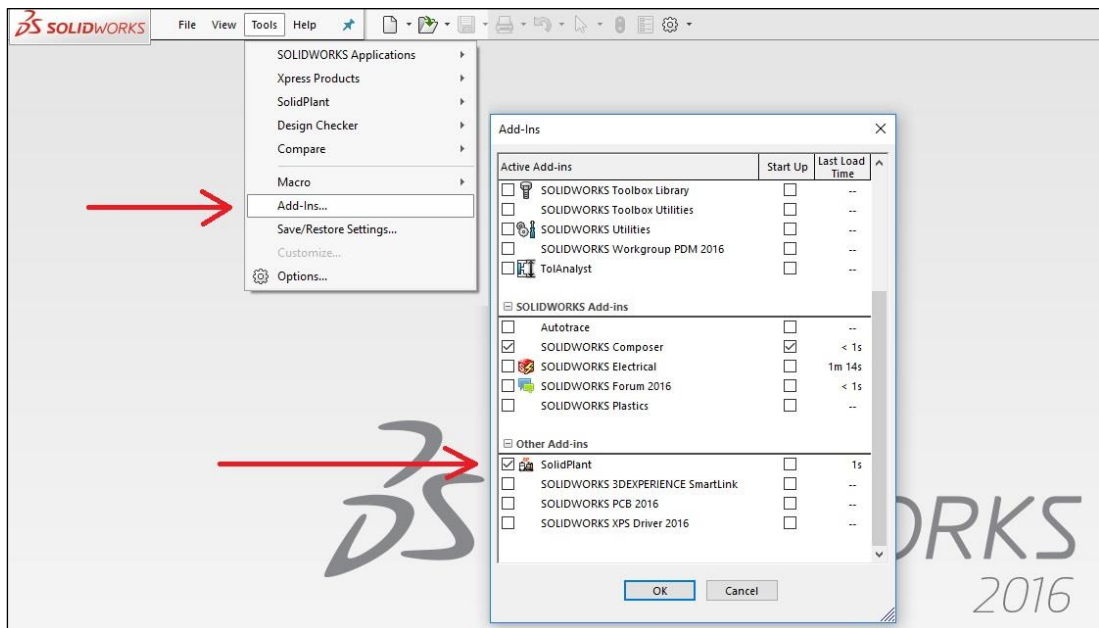

## SolidPlant Project Manager

On starting SolidPlant the **SolidPlant Project Manager** task pane will be automatically displayed by default on the right hand side of the screen. Through this interface it is possible to create new projects, open existing projects and create copies of projects.

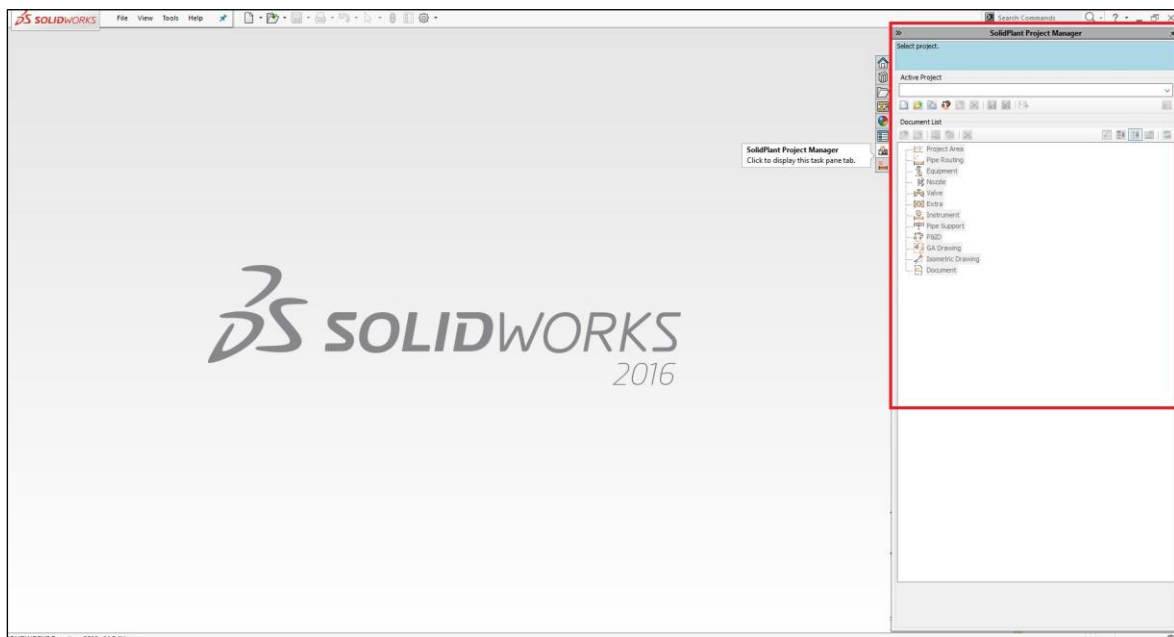

# Creating a new project

In SolidPlant 3D, the projects are assemblies of SOLIDWORKS consisting of many components, which can be parts or other assemblies, called subassemblies. The pipe lines and equipment created with SolidPlant 3D are subassemblies and the structure models can be parts or subassemblies.

## 1. Click New project... command.

To create a new project with SolidPlant 3D, click **SolidPlant Project Manager** task pane > **New project...** .

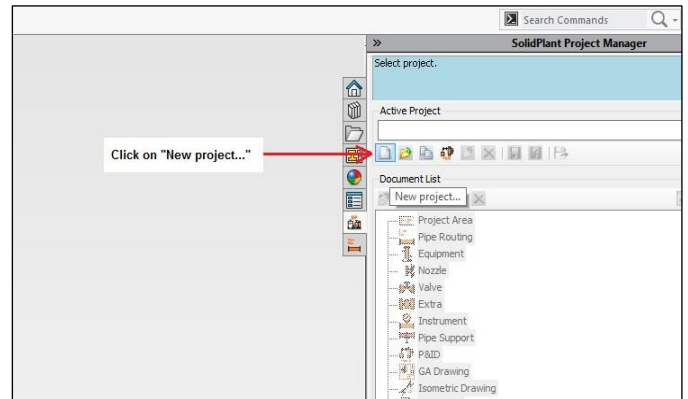

When prompted the **Create new project** dialog box, the user can define the fields **Project Name**, **Project Description** and **Directory**, where the project will be located.

On **Project Unit** area is displayed the three different types of system of units in which a project can be defined. Once the project has been created, the project unit can't be changed anymore.



Option	Description
<b>Imperial</b>	Imperial system of unit
<b>Metric</b>	International system of unit
<b>Mix-Metric</b>	A combination of imperial and metric units. Nominal diameter is on imperial unit and the rest of the values are on metric unit (length, weight, etc.)

## 2. Define the project properties.

Add the values on below for the property fields and option required.

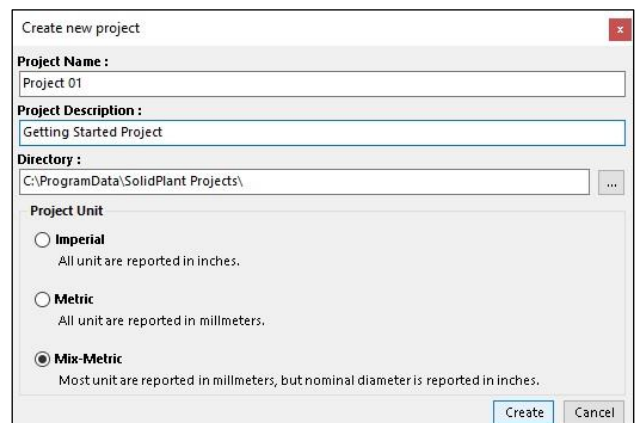
- **Project Name:** Type **Project 01**.
- **Project Description:** Type **Getting Started Project**.
- **Directory:** C:\ProgramData\SolidPlant Projects
- **Project Unit:** Select option **Mix-Metric**.



3. Click **Create**  and the project assembly will be displayed.
4. Click **Save**  on the **Standard** toolbar.

## Open a project

There are two ways to open a project.

- From the dropdown menu **Active Project**, it will list all the projects created previously. Select a project name and it will be opened.

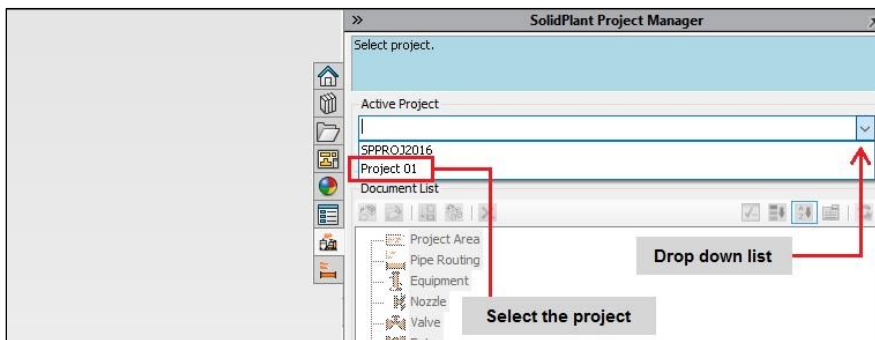

- Click **SolidPlant Project Manager** task pane > **Open project...** .

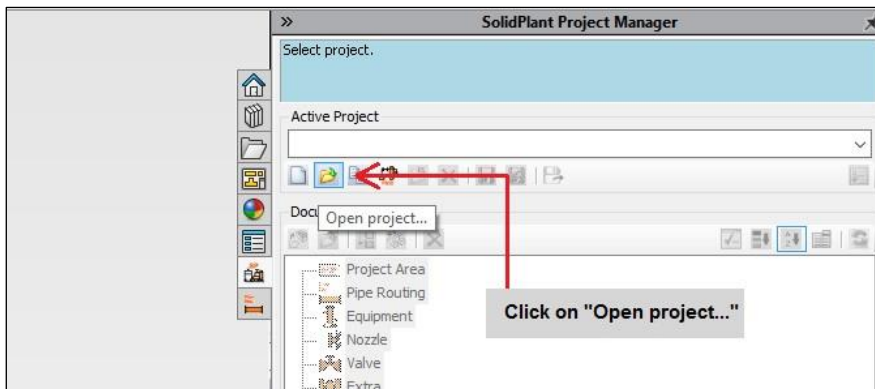

When prompted the browse window, the project can be opened via two different types of files within the project folder. It doesn't matter which type of file the user chooses that the project will be opened.

By default the project folder is located in `C:\ProgramData\SolidPlant Projects`.



- **Via .mdf file.**

SolidPlant 3D is a database driven system and uses Microsoft SQL Server 2014 as a relational database management system. The .mdf file of the project is used by Microsoft SQL Server for storing the database files and Schema.

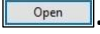
Browse into the project folder that we have created previously, select `Project 01.mdf` file and click **Open** .

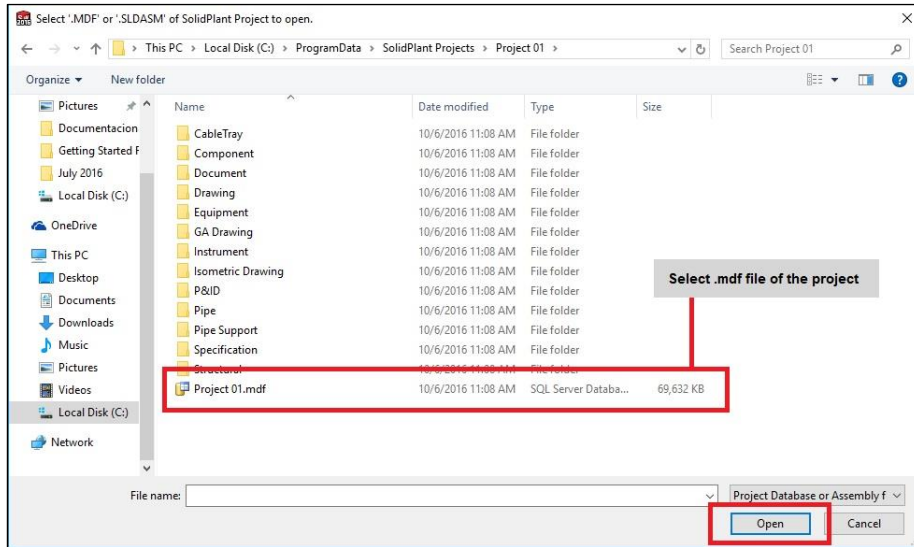

- **Via .SDASM file.**

The .SDASM file is the SOLIDWORKS assembly document, so that the project can be opened from the project assembly as well.

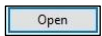
Select `Project 01.SDASM` file located in the `Drawing` folder within the project folder, and click **Open** .

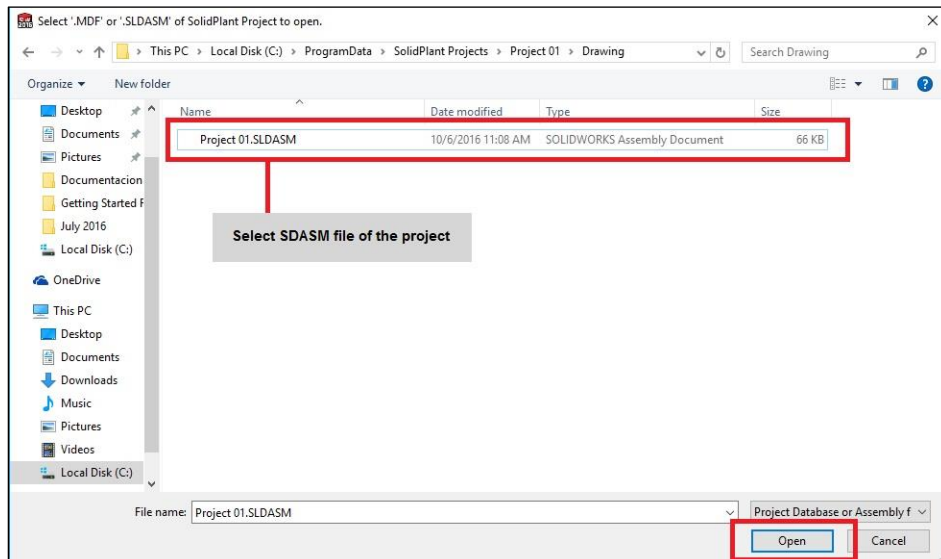





Automatically, once the project has been opened, it will be listed on the dropdown menu **Active Project** on the task pane **SolidPlant Project Manager**.

## User Interface

The SolidPlant 3D user interface is fully integrated within SOLIDWORKS interface. SolidPlant 3D has added two side **Task Panes** on the right hand side, and six **Application Tabs** on the top side in the CommandManager menu of SOLIDWORKS.

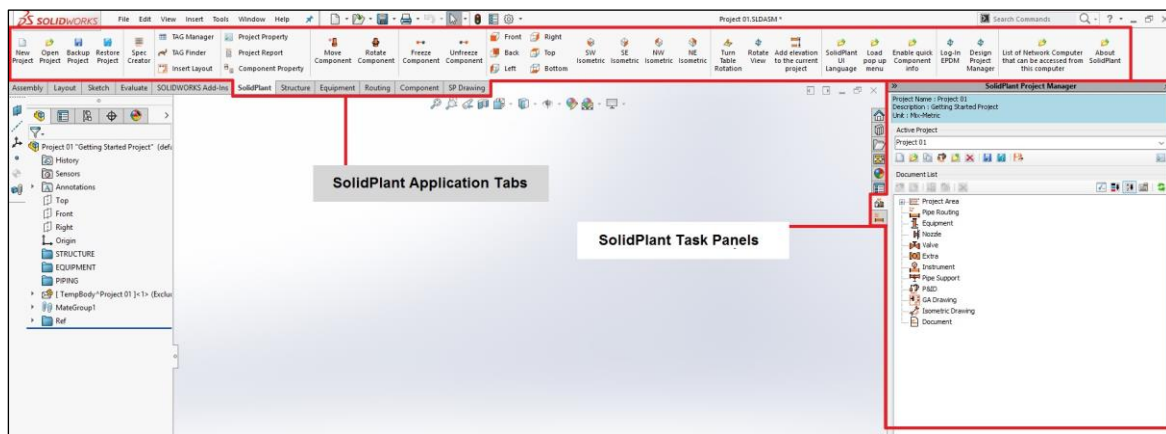

## Application tabs

There are six tabs available in SolidPlant 3D on the CommandManager of SOLIDWORKS that is a context-sensitive toolbar. When you click a tab below the CommandManager, it dynamically updates based on the toolbar the user wants to access.

### SolidPlant tab

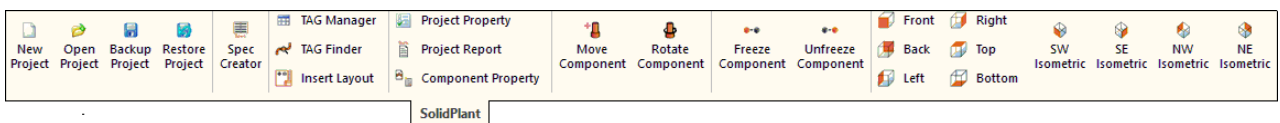

Provides a number of commands related to the management of the project, different views, access to SpecCreator application, project reports...

### Structure tab



This toolbar includes commands to create structure 3D grids, insert structure profiles, automatic generation of structure models (stairs, ladders, platforms, handrails, etc.), cutting list report...



## Equipment tab

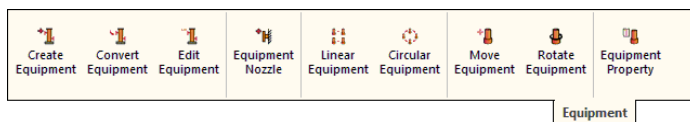

This toolbar includes commands to create equipment from the SolidPlant libraries, convert equipment, edit equipment, management of the equipment nozzles, creation of linear and circular patterns...

## Routing tab

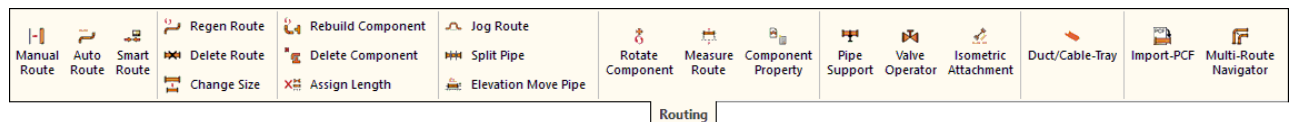

This toolbar contains all the tools necessary to create and edit the pipe lines, as well as commands to add pipe supports and valve operators, component properties...

## Component tab

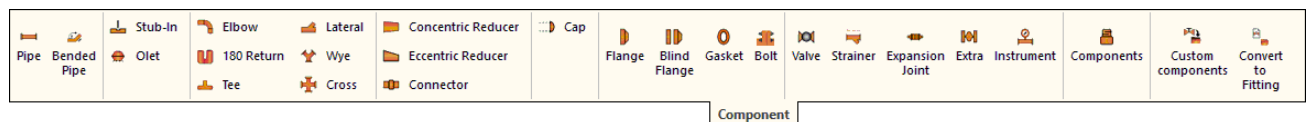

Provides a number of commands related to the piping components (elbow, flange, tee, instrument, valve, etc.), stub-in...

## SP Drawing tab

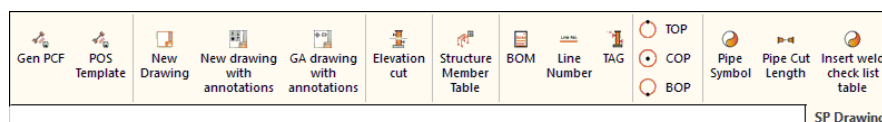

The last toolbar includes the automatic generation of isometric drawings, commands to create different type of drawings, bill of material, TAG annotations...

## Task Panes

There are two task panes available in SolidPlant 3D on the Task Pane of SOLIDWORKS on the right hand side of the interface. Selecting any of the SolidPlant tabs, the task pane dynamically updates according to the users' needs .



When opening a project in SolidPlant 3D, all the commands and features of the two SolidPlant task panes will be dynamically updated and made available.  
When there is no project opened, just a few commands on the **SolidPlant Project Manager** pane will be available.



## SolidPlant Project Manager task pane

When opening a project, the number of commands available is automatically updated in order to provide the tools to manage the project.

The node tree **Document List** is displaying all the tags of the components and the documentation generated in the project sorted by type.

Type	Components
<b>Pipe Routing</b>	Pipe lines.
<b>Equipment:</b>	Pumps, Exchangers ...
<b>Nozzle</b>	Nozzle Equipment.
<b>Valve</b>	Valves and Control valves.
<b>Extra</b>	Strainers, Spacers...
<b>Instrument</b>	Gauges, Thermowells..
<b>Pipe Support</b>	Pipe Supports.
<b>GA Drawing</b>	.SLDDRW files.
<b>Isometric Drawing</b>	.PCF, .DWG, .SLDDRW files.
<b>Document</b>	.XLS, .docx, .PDF files...

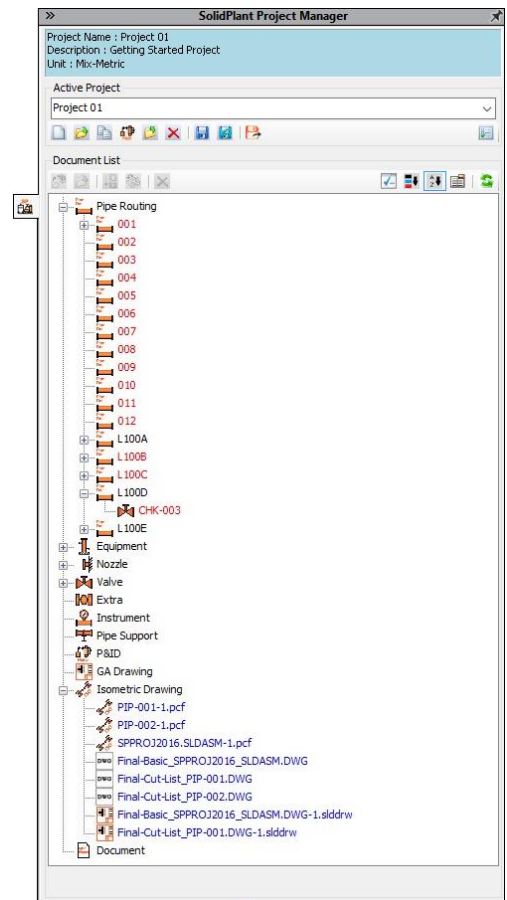

There are three different colors which are showing the status of each tag in the project.

**Red:** Just the data value is in the project database.

**Blue:** There is a 3D model created ready to bring into the project.

**Black:** The component is in the project assembly.

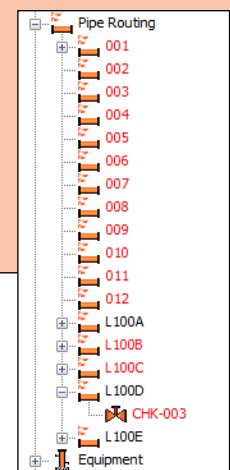

## SolidPlant Pipe Routing task pane

This interface is divided up into four main sections providing the tools to create pipe lines as well as to edit the values of the active pipe line, etc.



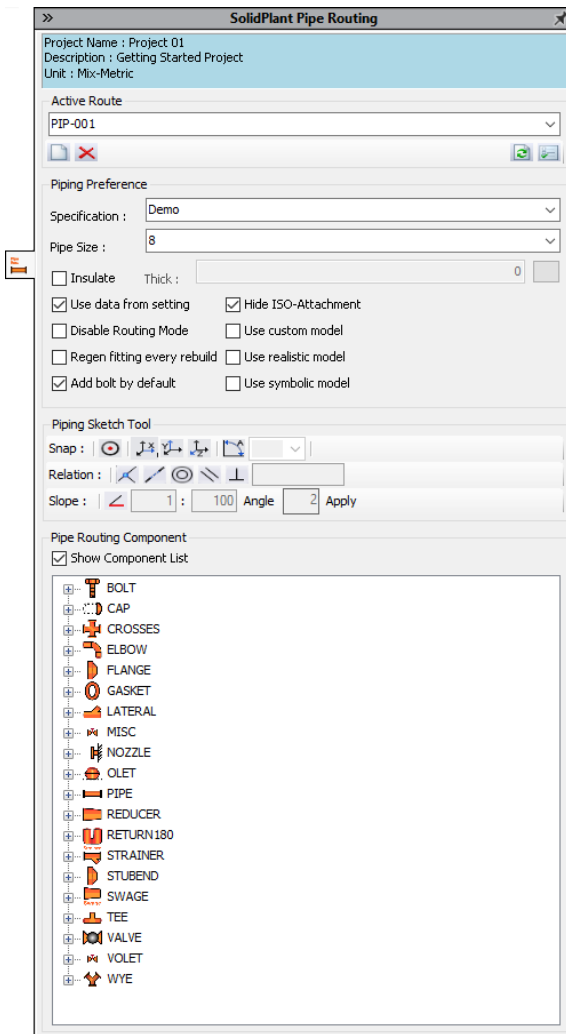

### Active Route

The dropdown menu displays the active line in use.

- New pipe model...:** For creating a new line.
- Delete pipe model...:** For deleting the current line.

...

### Piping Reference

**Specification:** Dropdown menu displaying the piping specification in use.

**Pipe Size:** Dropdown menu displaying the pipe size in use from the available sizes contained into the specification.

The check boxes enable or disable different features according to the needs of the user.

### Piping Sketch Tool

**Snap:** Snap to center, Along X Axis...

**Relation:** Coincident to entity, Parallel to entity...

**Slope:** Scale factor, Angle degrees of the slope.

### Pipe Routing Component

The node tree displays the piping components available within the current piping specification (e.g. **Demo**) and pipe size (e.g. **8"**).

## Creating structures

There are many different tools to create steel structures with SolidPlant 3D and all are displayed in the **Structure** tab. Depending on the command type that is used a variety of task panes, wizards, windows, etc. will become available to accomplish the job.

### Structure 3D Grid command

To create a Structure 3D Grid:

1. Click **Structure** Tab > **Structure 3D Grid**.

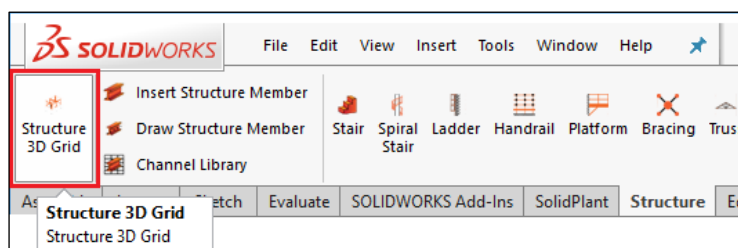

The **3D Grid** task pane will be automatically displayed on the left hand side in the PropertyManager of SOLIDWORKS, and a 3D grid frame will be placed by default on the **Origin** point of the assembly project.

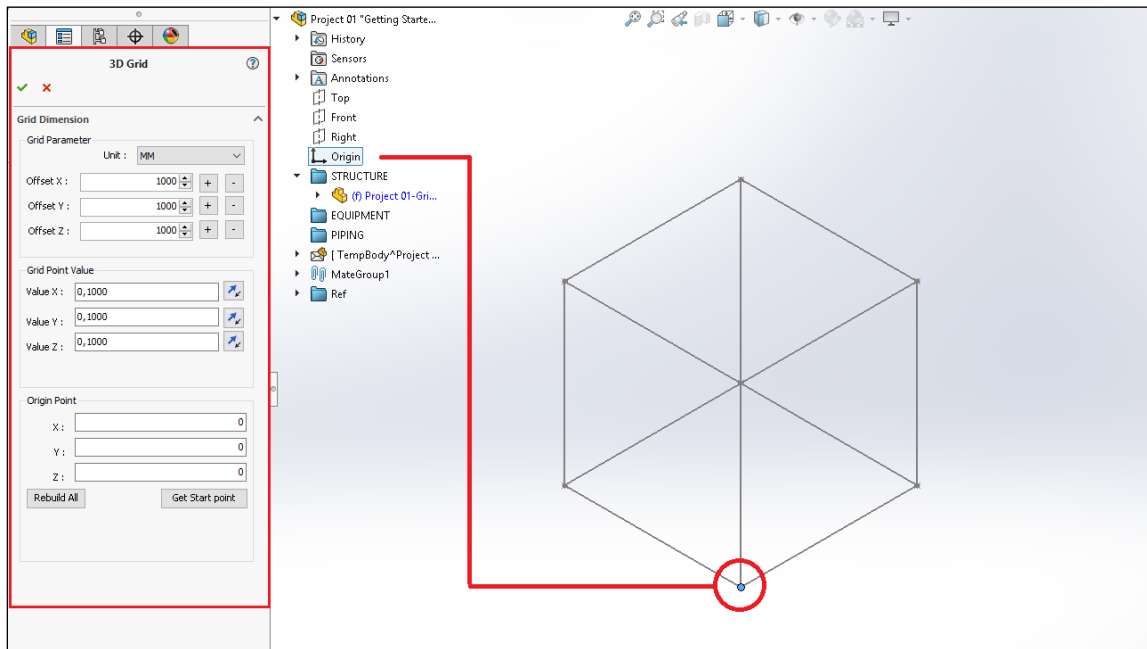

The origin point of the 3D grid frame can be controlled in two different ways.

- **Via Origin Point fields.**

Type any random value along the axis fields **X**, **Y** and **Z** to test.

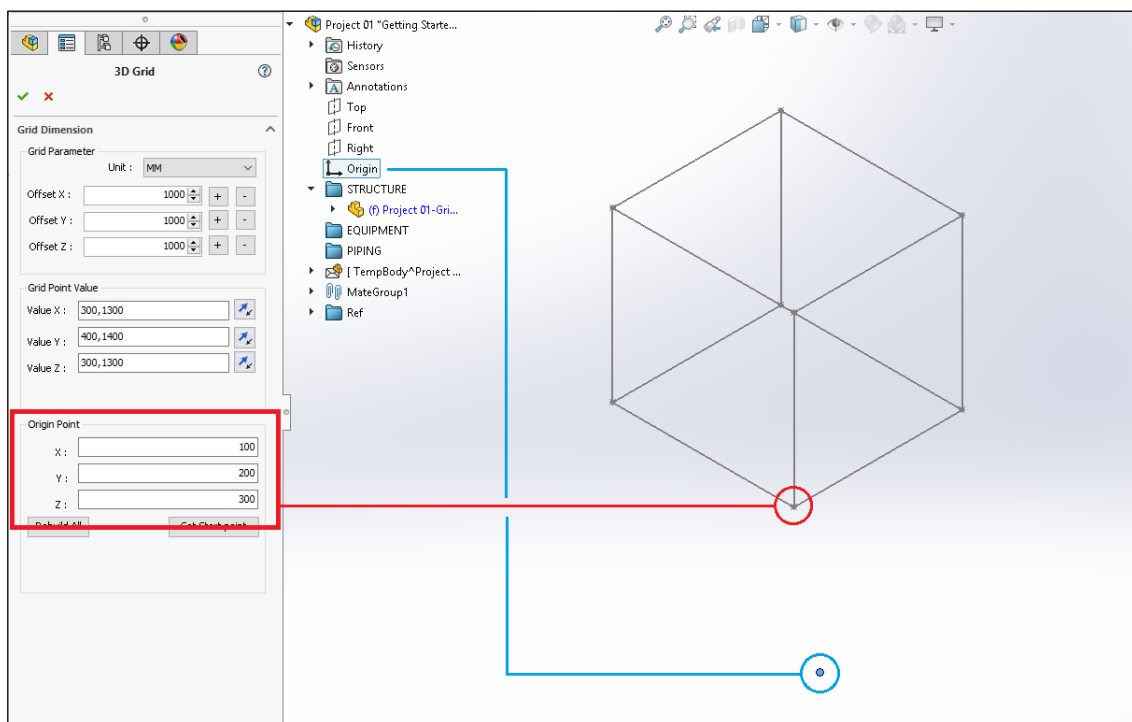



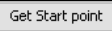

In order to update the 3D grid entity with the new values added into the parameter fields, after typing the value, the user must click on any other field within the **3D Grid** pane and automatically the grid entity will be updated.

- **Via Get Start point command.**

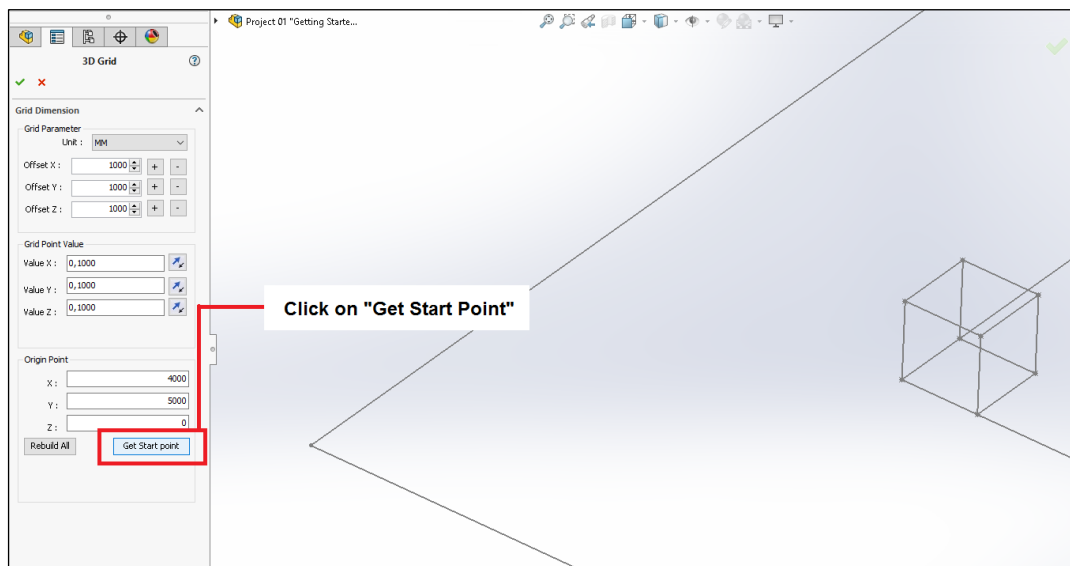
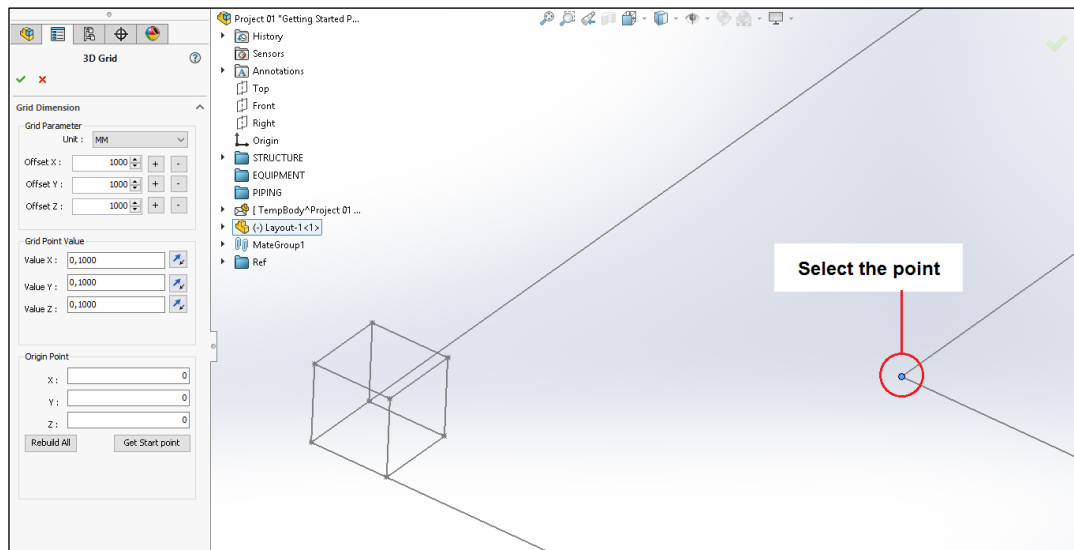
By selecting any sketch point within the project assembly, and then click **3D Grid** task pane > **Get Start point** , the 3D grid will be placed automatically on the point selected.



By typing values on the fields **Value X, Y and Z** grouped in the **Grid Point Value** area, the user controls the dimensions along the axis of the 3D Grid. With this command  the user changes to the opposite direction along the selected axis.



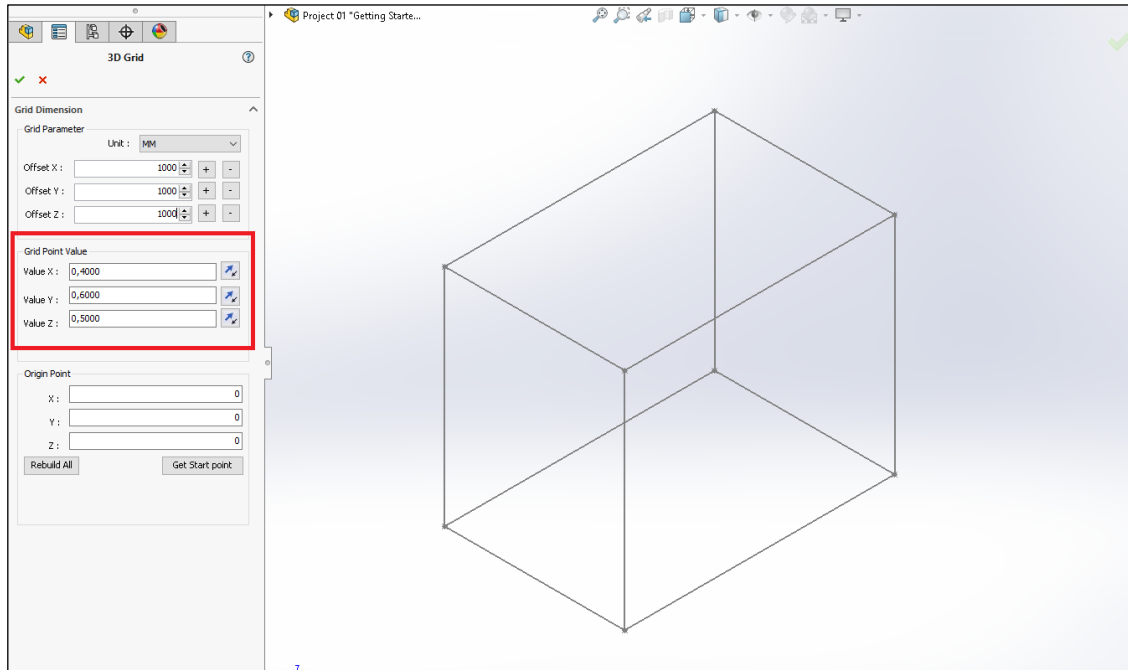

To add new levels in the 3D grid, the user can type any value on the fields **Offset X, Y and Z** on the Grid Parameter area, and then click command **+** to add a new level. The offset value will be added after a comma into the fields **Value X, Y and Z** on the **Grid Point Value** area, and the 3D grid will be updated automatically. Click command **-** to delete a level.

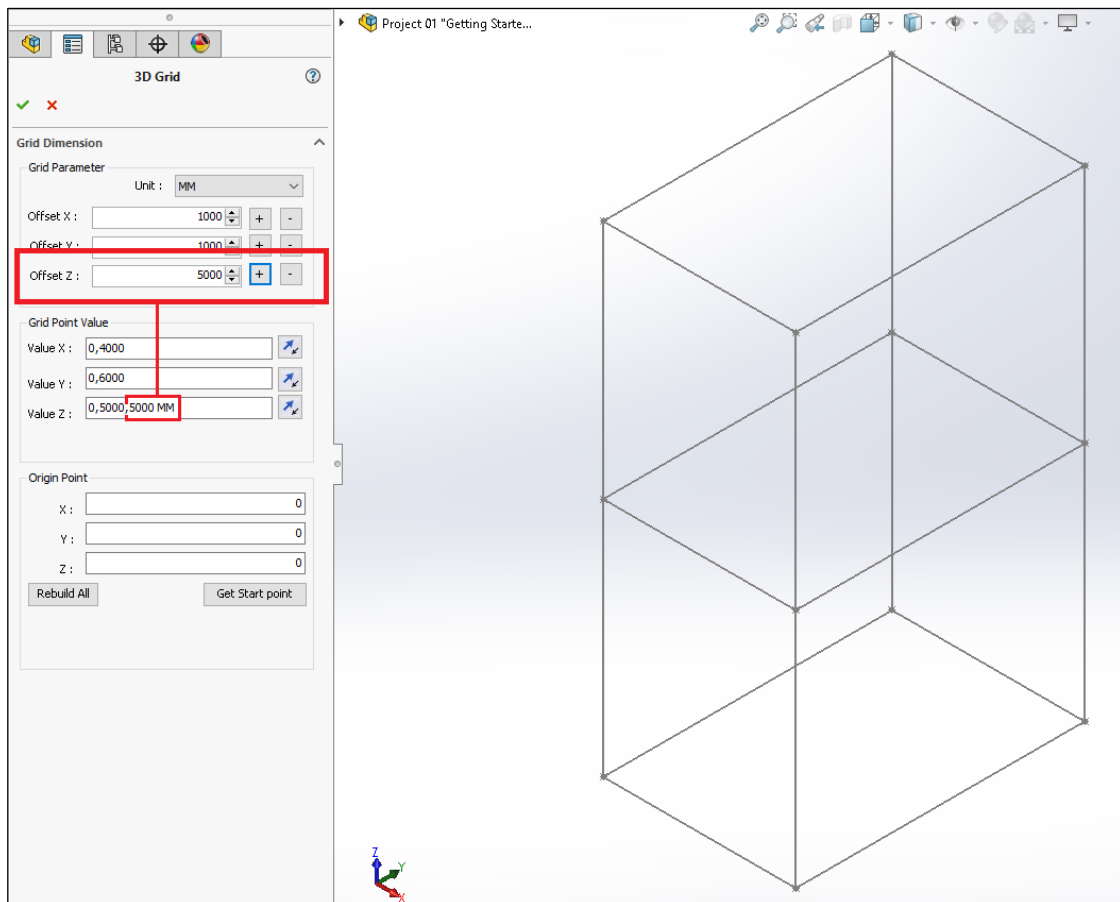

Also the user can change manually the values in the fields **Value X, Y and Z** on the **Grid Point Value** area.

- Add new levels by typing a comma after any value and type a new value of the level.
- Delete manually any level by suppressing its value.
- Edit any level by changing the value of an existing one.

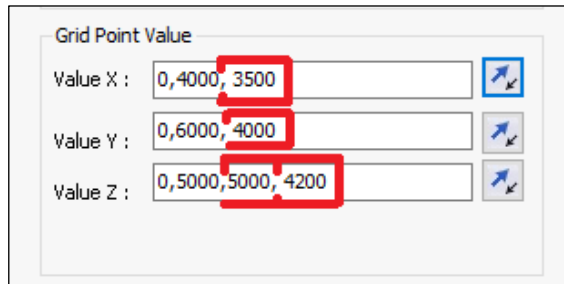

Grid Point Value

Value X : 0,4000,3500

Value Y : 0,6000,4000

Value Z : 0,5000,5000,4200

## 2. Add the values on the Grid Point Value fields.

Type the values on below to define the 3D grid entity.

- **Value X:** 0, 4000
- **Value Y:** 0, 6000
- **Value Z:** 0, 5000, 5000

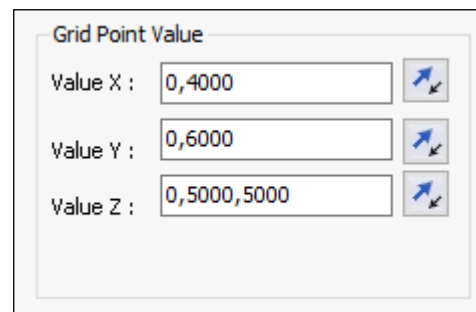

Grid Point Value

Value X : 0,4000

Value Y : 0,6000

Value Z : 0,5000,5000

3. Click **3D Grid** task pane > **OK**  to confirm and close the pane.

### To edit again the 3D grid created.

Click on any sketch line of the grid and then click **Structure Tab** > **Structure 3D Grid**. The **3D Grid** pane will be displayed again for further editing.

## Insert Structure Member command

To insert structure profiles:

### 1. Select any sketch line.

Select any sketch line contained into the 3D grid previously created.





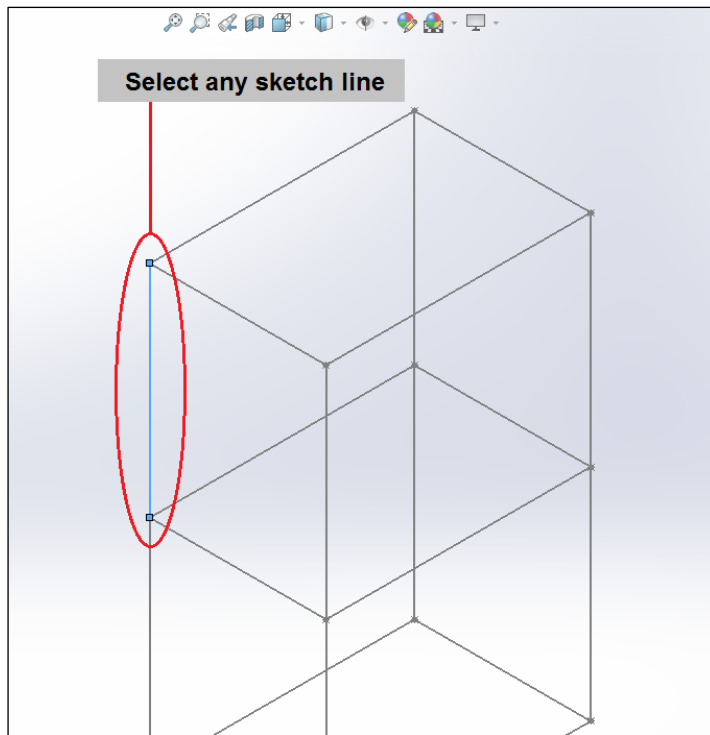

2. Click **Structure** Tab > **Insert Structure Member**.

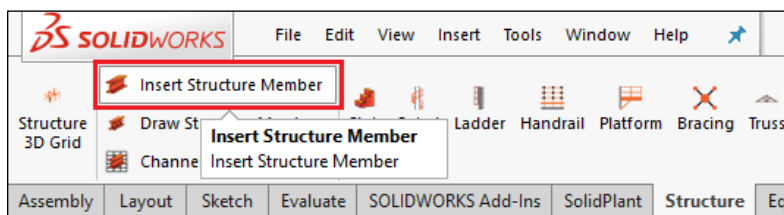

The **Structural Member** task pane will be automatically displayed on the left hand side in the PropertyManager of SOLIDWORKS. SolidPlant 3D provides, apart from what is already in SOLIDWORKS, a new wide range of standards, types of profiles and sizes of structural members.

The user can define the profile of the structure from the dropdown menus **Standard**, **Type** and **Size** in the **Selections** area.

The SolidPlant weldment profiles are located in:

C:\Program Files\SolidPlant\Structure\Weldment Profiles.

By selecting the sketch lines, the profiles will be added automatically. All structural members in a single group must use the same profile.

3. **Define the values of the weldment profile.**

Select the values on next page from the dropdown menus.



- Menu **Standard**: Select **ANSI Inch Standard**.
- Menu **Type**: Select **W Section – Configured**.
- Menu **Size**: Select **W10X88**.

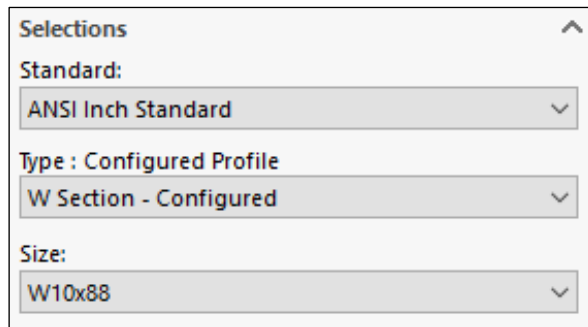

#### 4. Select the vertical sketch lines.

Select all the vertical lines one by one in order to add the columns into the 3D grid.

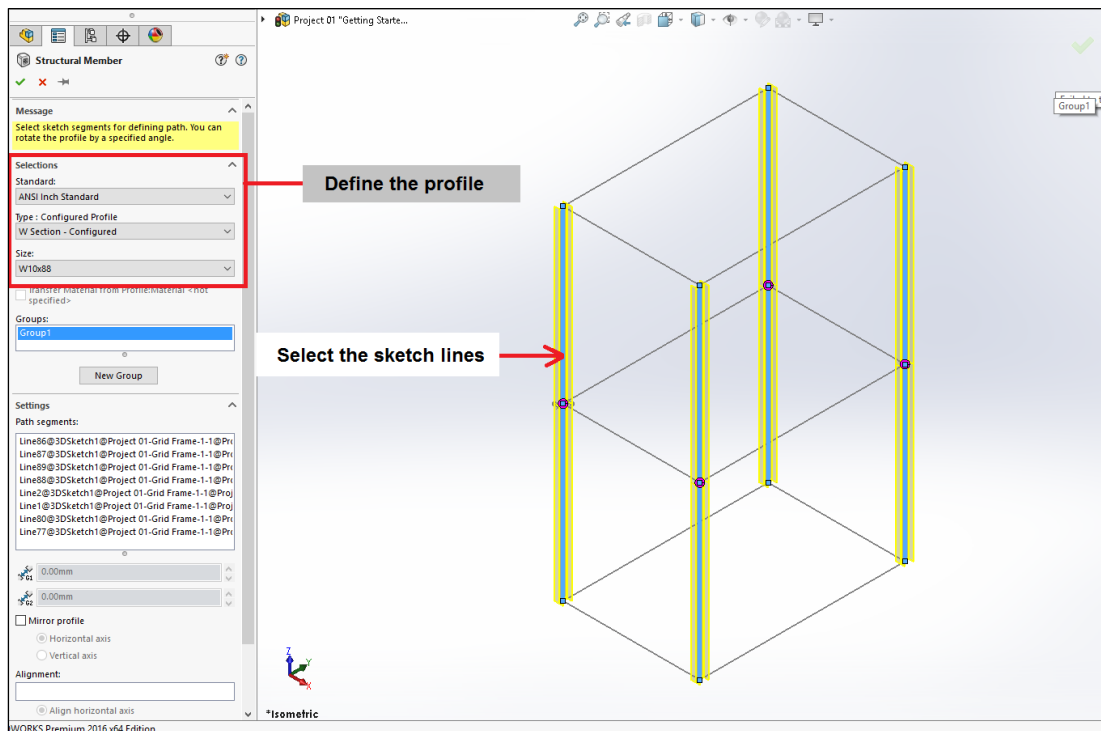

5. Click **Structure Member** task pane > **Ok**  to confirm.
6. Add also the structure beams using the same procedure.
7. Click **Edit Mode** symbol to exit once the structure is finished.

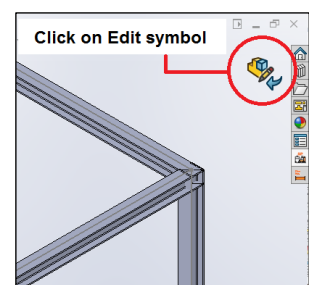

# Structure modelers

A number of structure modelers are available in the **Structure** tab to create automatically different type of structures easily like stairs, handrails, platforms, etc.

The way of working is similar on most of the modelers. As a sample, the user will learn to use the **Stair** modeler.

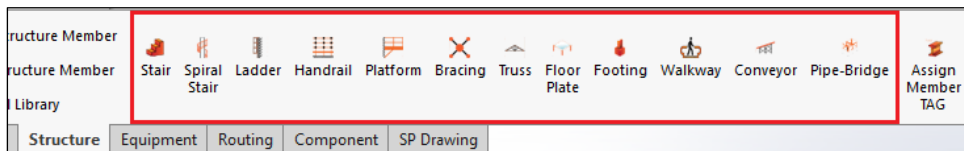

## Stair command

To create a Stair:

1. Click **Structure** Tab > **Stair**.

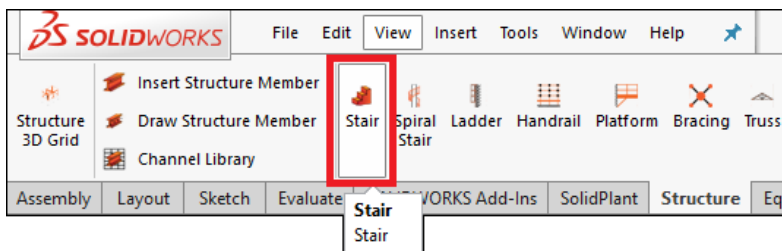

The user is on 3D sketch mode and the tool **Line**  is active. Drawing a single line will mark the start point of the stairs, and its dimension will set the width of the model.

2. **Sketch a line.**  
Sketch a line on the edge of the beam and set a dimension of 1000mm length.

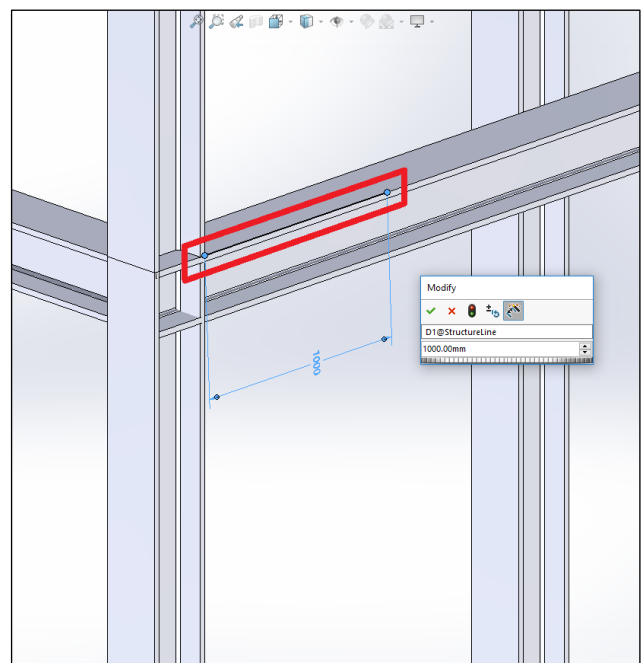

### 3. Exit from **Sketch** mode.

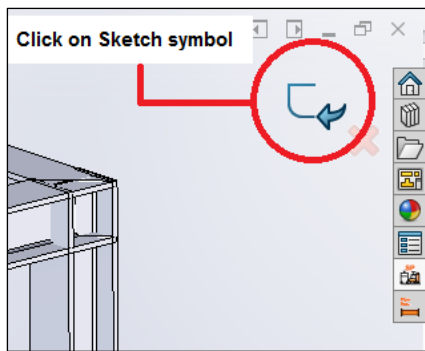

The window **Stair Dimension** will be displayed and the default stair structure will be created from the line previously drawn.

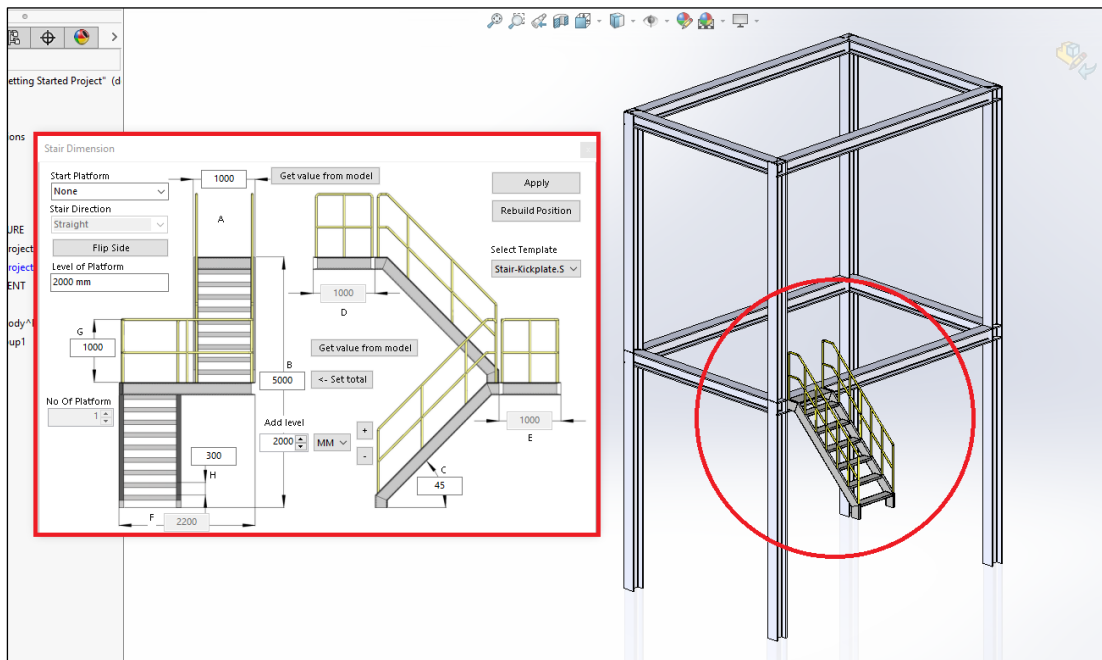

Setting the parameters on any of the available fields, and clicking **Apply**  , the stair will be updated automatically.

### 4. Define the parameters of the stair.

- **Start Platform** dropdown menu: Select **90 Degrees Left**.
- **Level of Platform**: Type **2500, 2500**.  
It can be added as many as levels needed after each comma.
- **Start Direction** dropdown menu: Select **180 Degrees Right**.

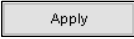

- Click **Apply**  to update the 3D model of the stair.

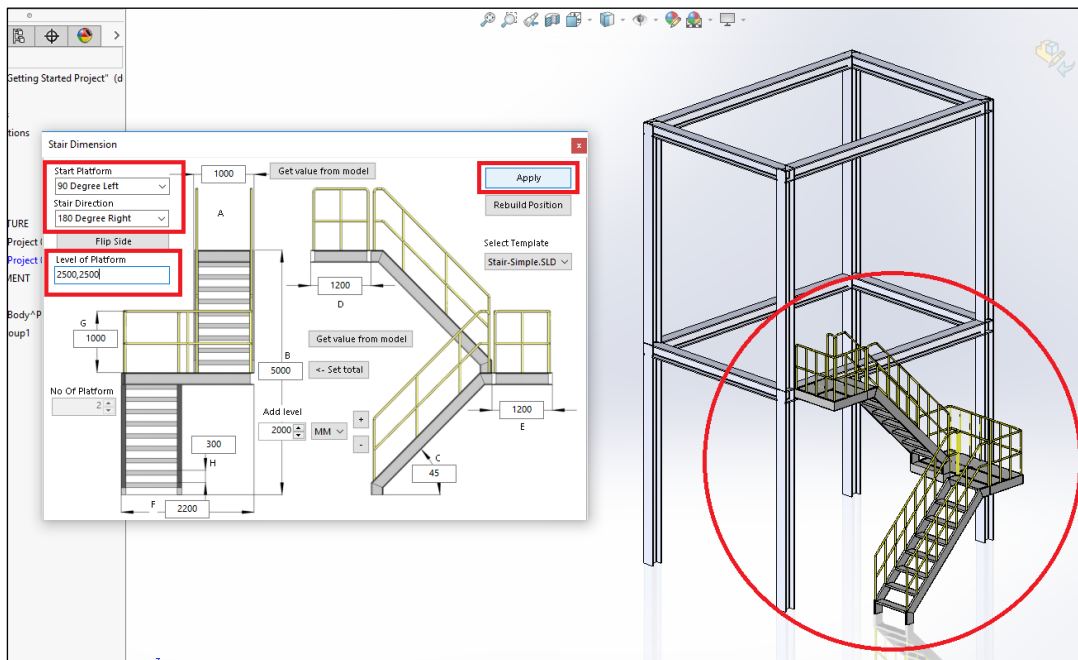

Moving to a new position the start sketch line, and then clicking on **Rebuild Position** button, the stair will move on to the new position. The `StructureLine` sketch is located into the stair assembly.

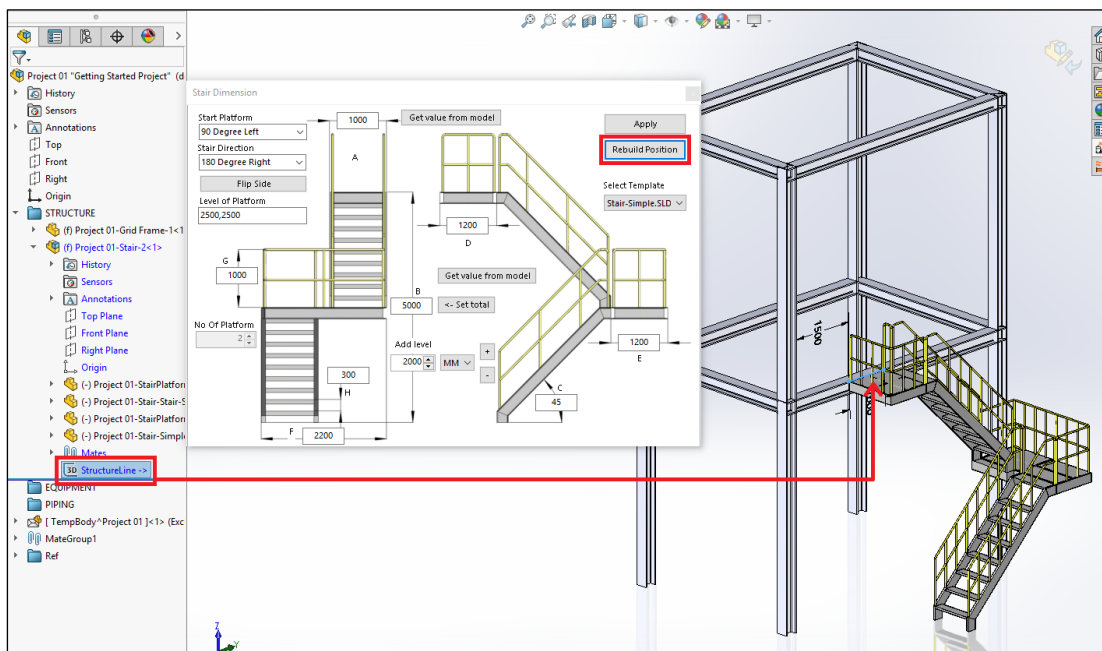

**To edit again the stair created.**

Select any part of the stair and then click **Structure** tab > **Stair**. The **Stair Dimension** window will be displayed again for further editing.



# Create equipment

SolidPlant 3D provides a full library of templates with all types of equipment fully parameterized which allows the user to easily change the main dimensions. Apart from the library of SolidPlant 3D, the user can use his own designs and bring into the project any model, and intuitively assign the nozzles needed on the equipment.

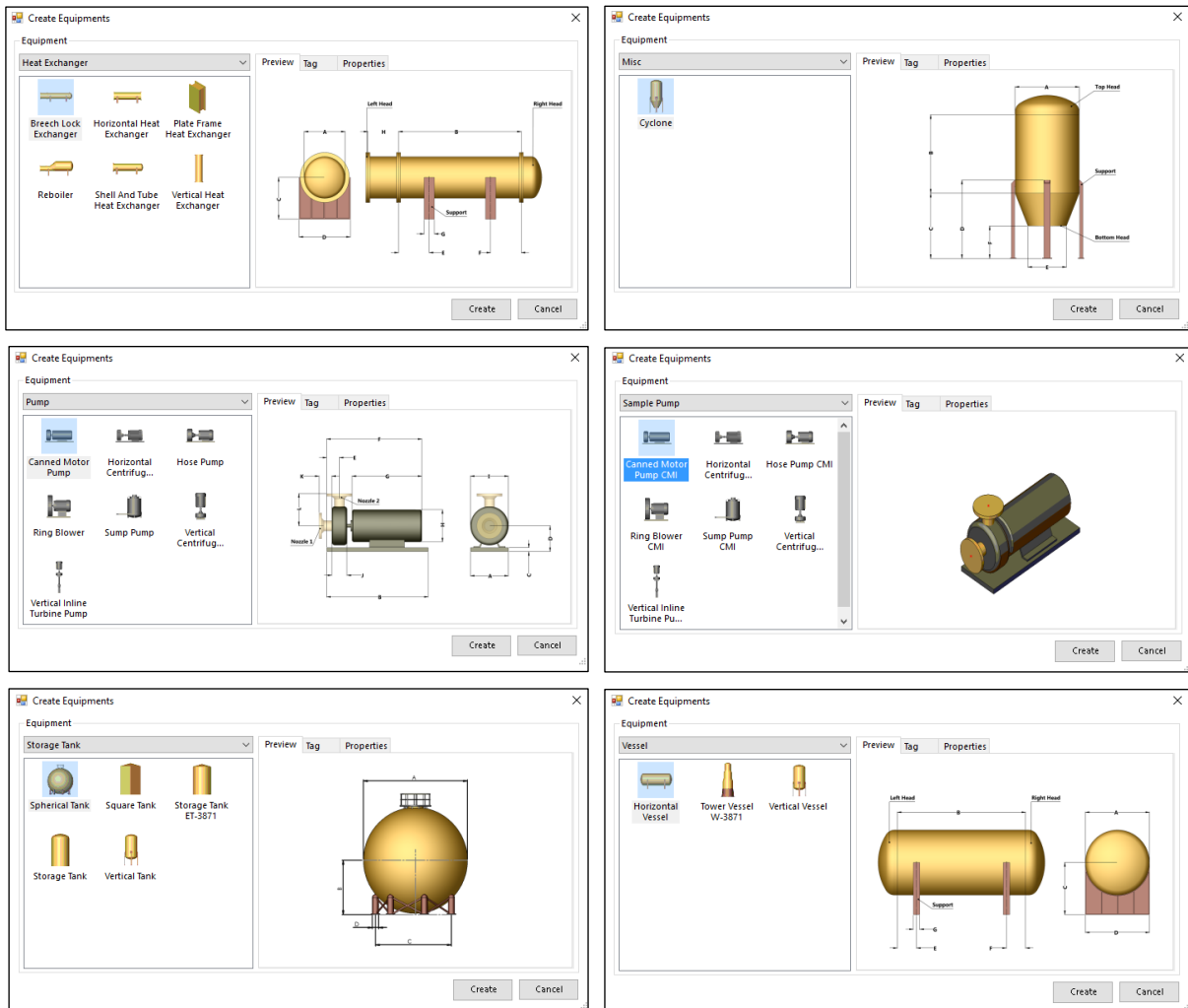

## Pump Equipment

To create a pump from SolidPlant 3D library:

1. Click **Equipment Tab > Create Equipment**.

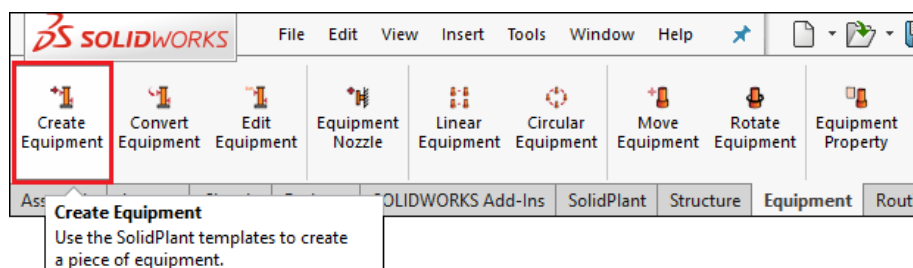

## 2. When prompted the window **Create Equipment**:

- From dropdown menu **Equipment**, select **Pump**.
- Select the icon **Horizontal Centrifugal Pump**.
- Click **TAG Property** .

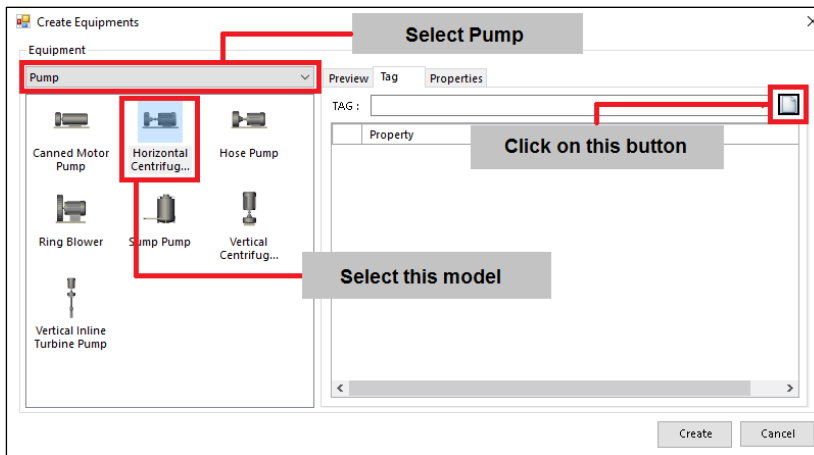

## 3. From the window **TAG Property**:

- **TAG** field: Type **PUMP-001**.
- **Description** field: Type **Pump Getting Started** (Optional).
- Click **Create**.

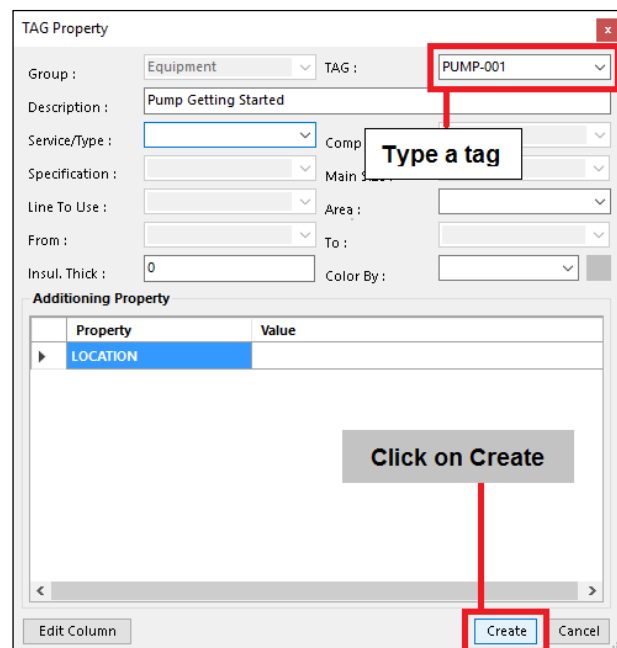

## 4. Click **Create** to confirm.

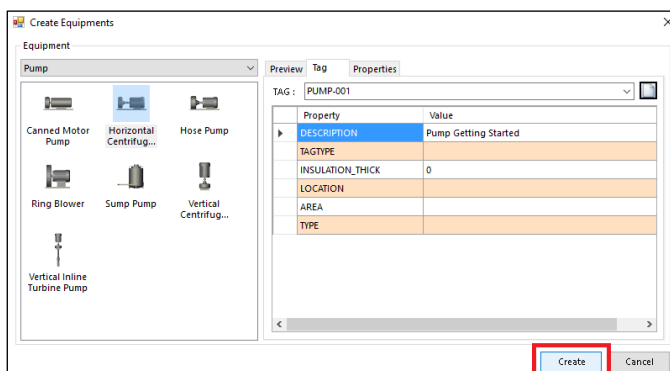

The new assembly model of the pump is opened along with the **Horizontal Centrifugal Pump** dialog box to define the dimensions from **A** to **L** fields.

### 5. Set the dimensions of the pump.

Type the values shown on below picture into the dimensions fields on the Horizontal Centrifugal Pump window.

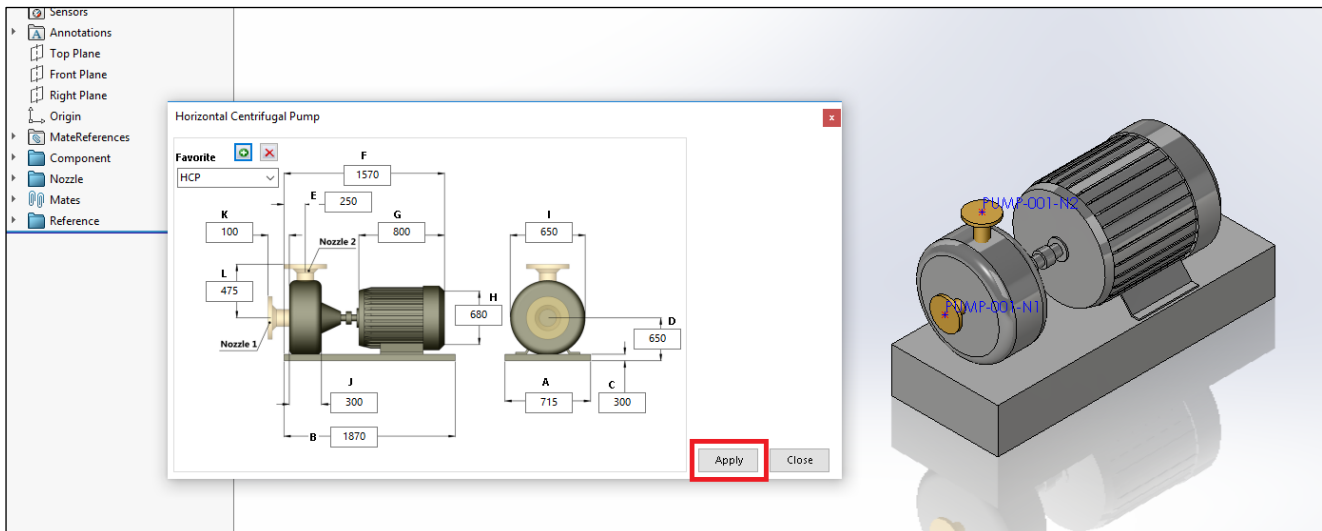

6. Click **Apply**  to update the model with the dimensions just set.

### 7. Create a favorite setting.

Type on **Favorite** field any name and then click **Add**  in order to save the current parameters of the pump. From the dropdown menu **Favorite** will list the newly created setting. Click **Delete**  to suppress the selected favorite.

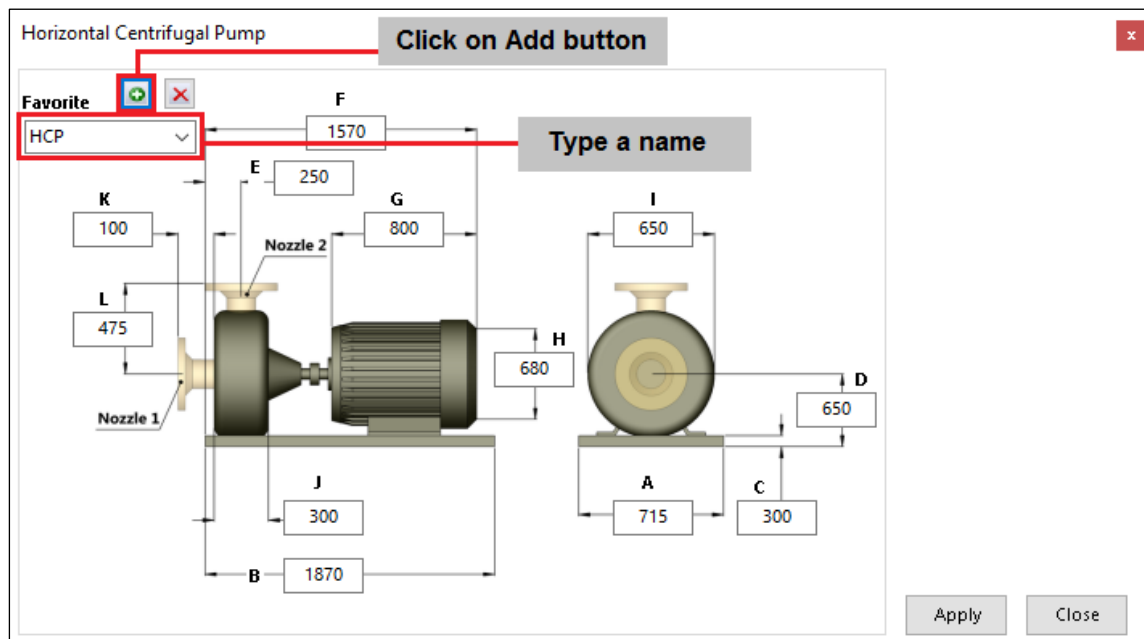



8. Click **Close**  on the **Horizontal Centrifugal Pump** dialog box.

The **Nozzle Component** task pane is displayed on the left hand side in the PropertyManager of SOLIDWORKS in order to set the parameters of the equipment nozzle.

By default this pump comes with two nozzles, the user can set the parameters of the existing nozzles by selecting from the **Tag** dropdown menu the available tags on the **Nozzle Data** tab.

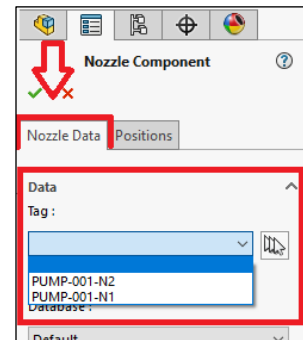

If the **Nozzle Component** task pane is not displayed in the PropertyManager, click **Structure** tab > **Equipment Nozzle** to display it.

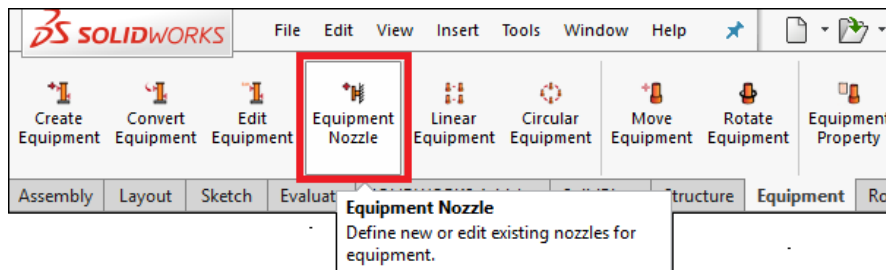

To edit again the pump dimensions, click **Equipment Tab** > **Edit Equipment** to access the **Horizontal Centrifugal Pump** dialog box for further editing.

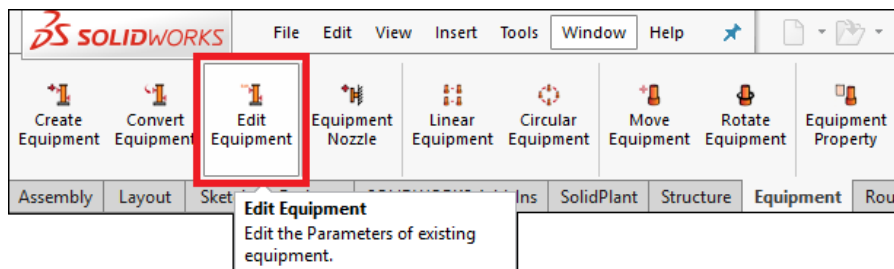

9. **Set the parameters of the nozzle pump PUMP-001-N1.**

Select the values on **Nozzle Data** tab in the **Nozzle Component** task pane.

- **Tag** dropdown menu: Select **PUMP-001-N1**.
- **Database** dropdown menu: Select **Demo** specification.
- **Size** dropdown menu: Select **6** inches.
- **End Type** dropdown menu: Select **FL** (Flange connection).
- **Selected Nozzle** list: Select **NON STANDARD 150LB FLAT FACE NOZZLE**.



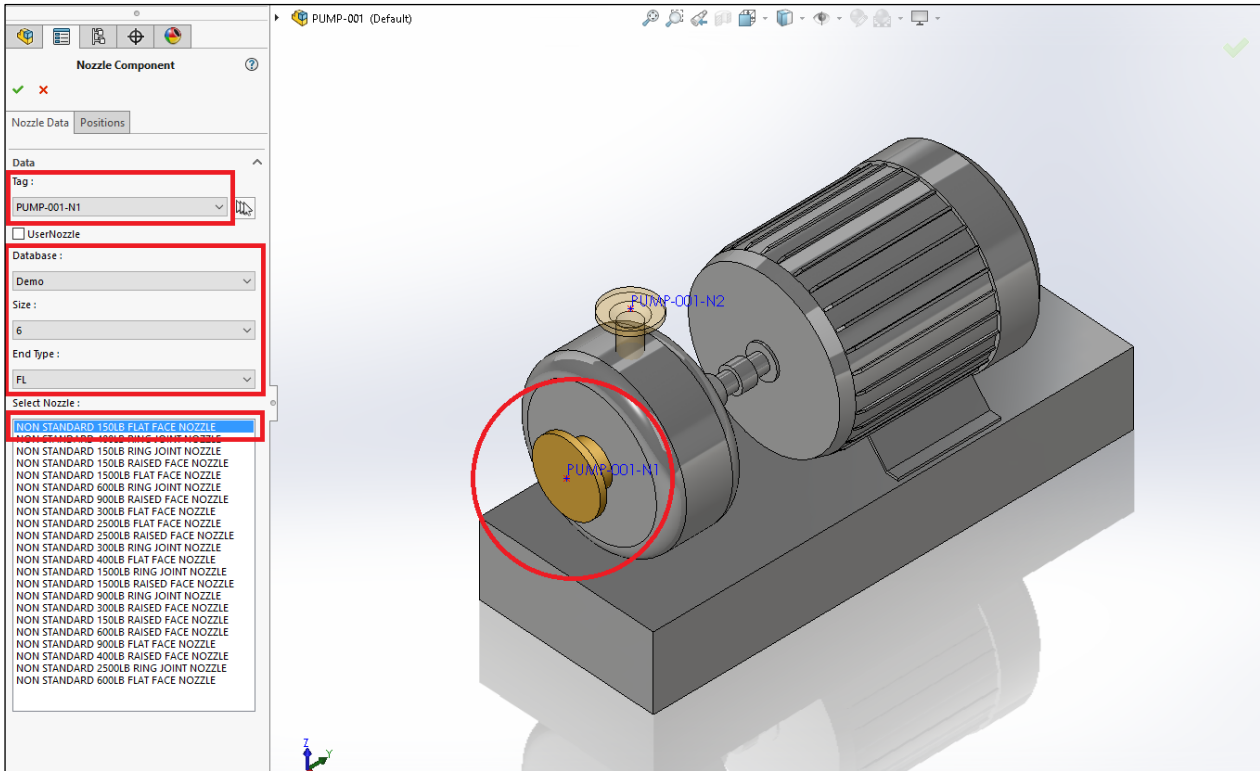

#### 10. Set the parameters of the nozzle pump PUMP-001-N2.

Select the values on **Nozzle Data** tab in the **Nozzle Component** task pane.

- **Tag** dropdown menu: Select **PUMP-001-N2**.
- **Database** dropdown menu: Select **Demo** specification.
- **Size** dropdown menu: Select **6** inches.
- **End Type** dropdown menu: Select **FL** (Flange connection).
- **Selected Nozzle** list: Select **NON STANDARD 150LB FLAT FACE NOZZLE**.

11. Click **Ok**  on the **Nozzle Component** task pane.

12. **Save** from the **Standard** toolbar and close the pump assembly.

Back to the project, on the **Document List** node tree is displayed the tag **PUMP-001**.

13. Click **Refresh** , if the tag is not displayed.

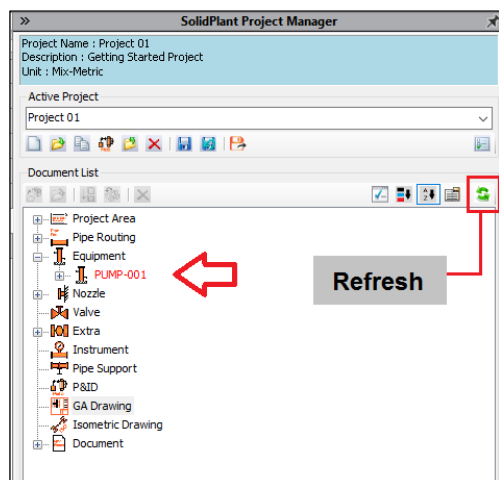

**14. Drag & drop the pump into the project assembly.**

Click on the tag **PUMP-001** on the **Document List** node tree with the scroll/middle mouse button and hold it pressed, then drag and drop the pump into the project assembly.

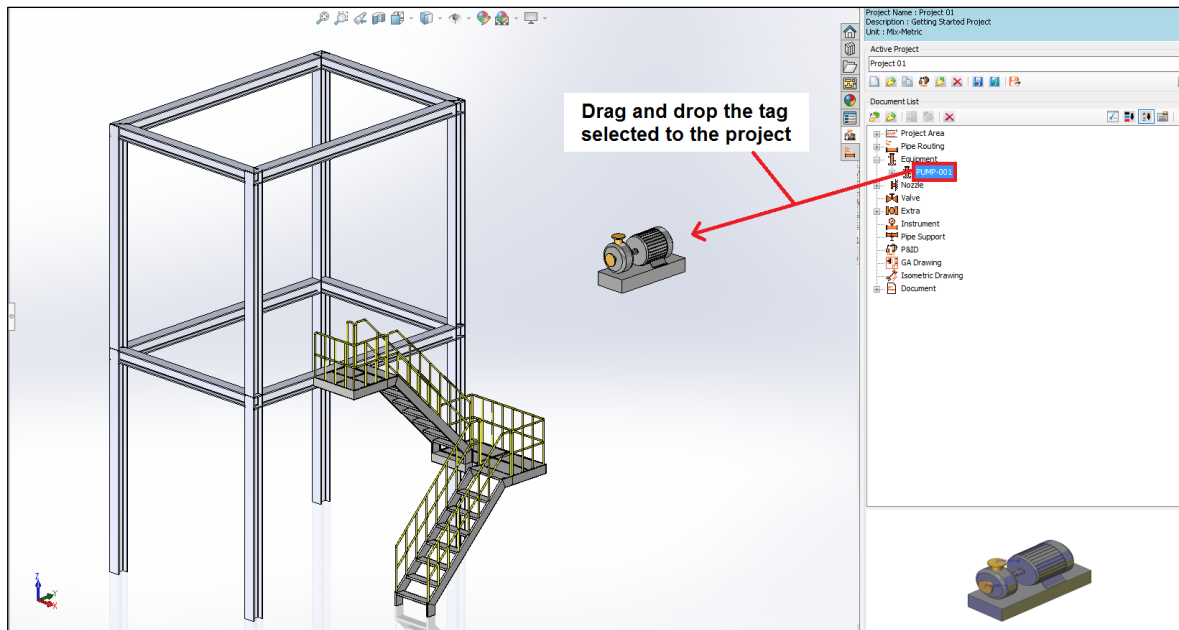

**15. Place the pump in the middle of the structure using SOLIDWORKS mates. Click **Refresh** button to update the status of the tag **PUMP-001** on the node tree.**

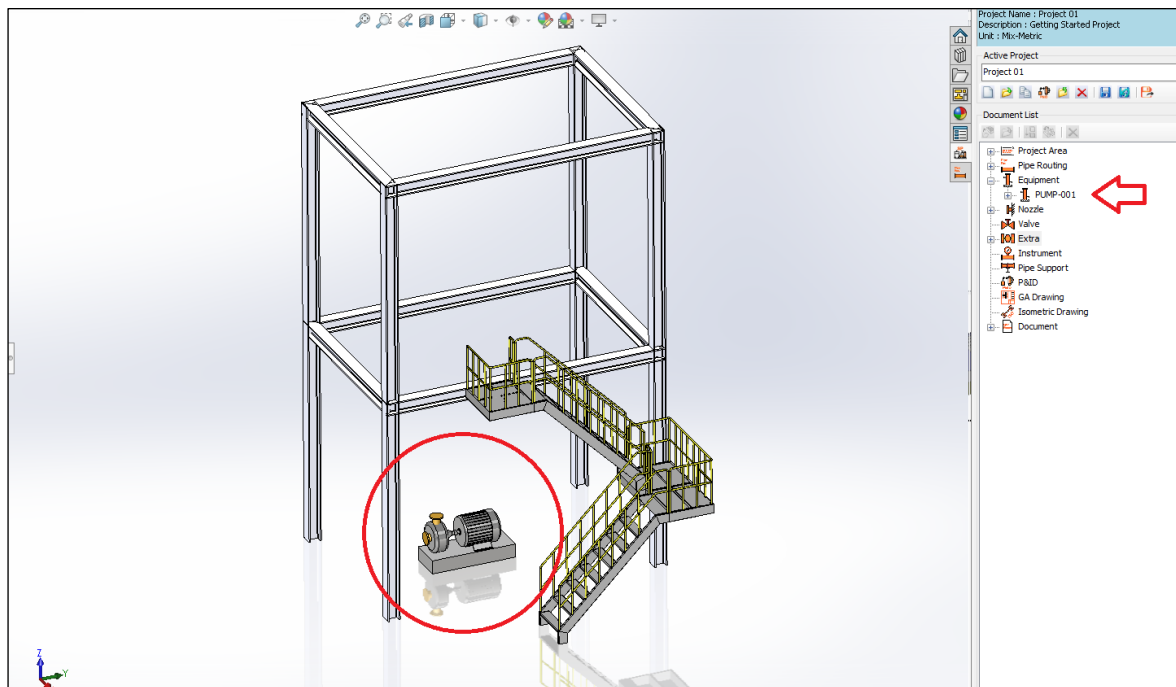

**16. Save the project on the **Standard** toolbar.**



### To access the pump again.

Click right mouse button on the tag **PUMP-001** on the **Document List** node tree and select **Open Component** from the shortcut menu in order to open and edit the pump.

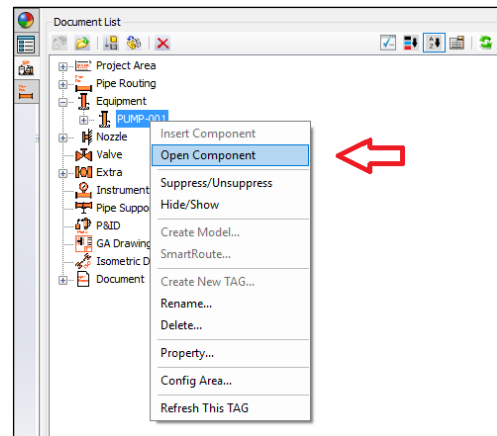

## Vessel Equipment

To create a vessel from SolidPlant 3D library:

1. Click **Equipment Tab > Create Equipment**.

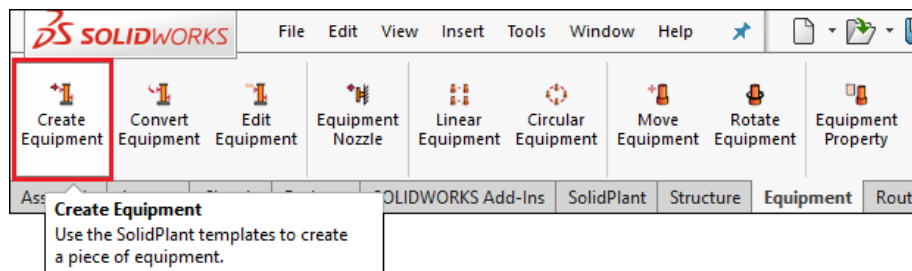

2. When prompted the window **Create Equipment**:

- From dropdown menu **Equipment**, select **Vessel**.
- Select the icon **Horizontal Vessel**.
- Click **TAG Property** .

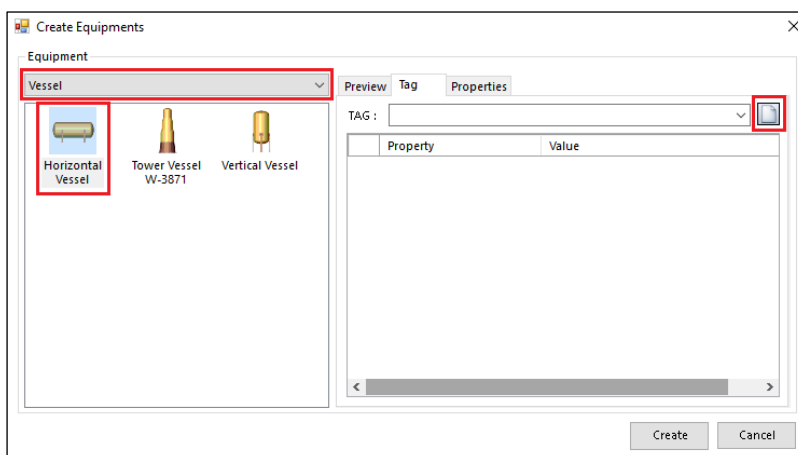

3. From the window **TAG Property**:

- **TAG** field: Type **V-001**.
- Click **Create**.

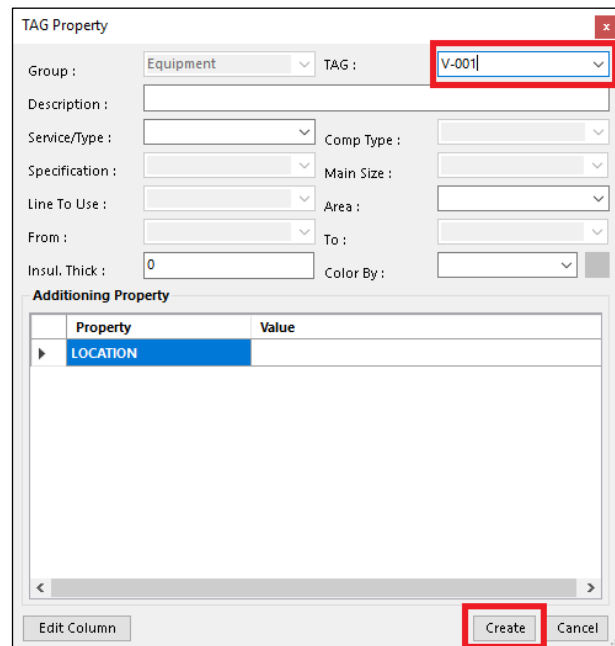

4. Click **Create** to confirm.

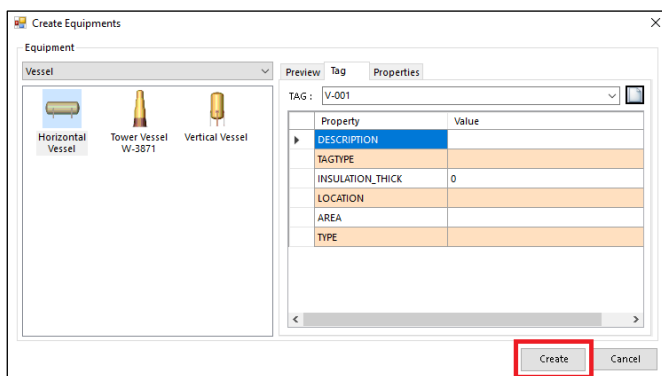

The new assembly model of the vessel is opened along with the **Horizontal Vessel** dialog box to define the dimensions from **A** to **F** fields.

5. **Set the dimensions of the vessel.**

Type the values shown on below picture into the dimensions fields on the **Horizontal Vessel** dialog box.

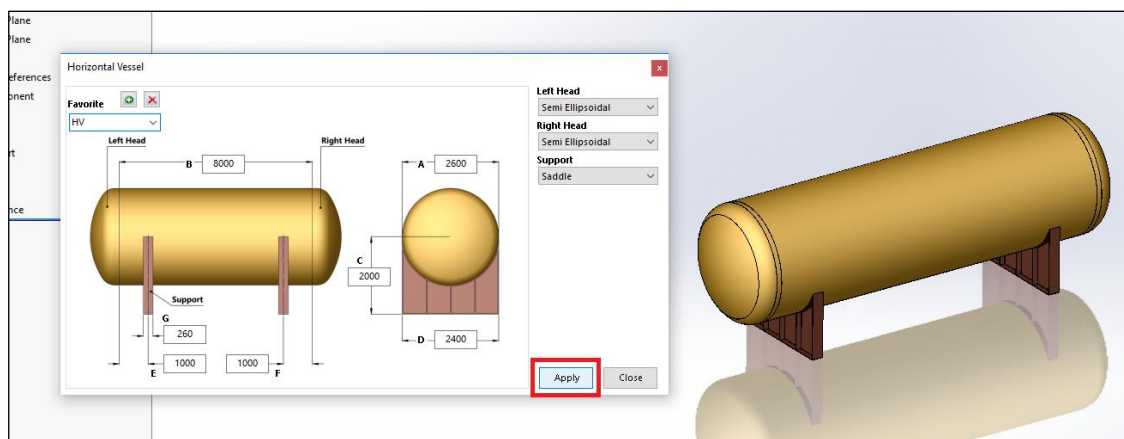

6. Click **Close** .

The **Nozzle Component** task pane is displayed on the left hand side. By default this equipment is without nozzle.

7. Click **New Nozzle**  and the **TAG Property** window will be displayed.

8. From the window **TAG Property**:

- **Tag** dropdown menu: Type **V-001-N1**.
- **Database** dropdown menu: Select **Demo** specification.
- **Size** dropdown menu: Select **6** inches.
- Click **Create**.

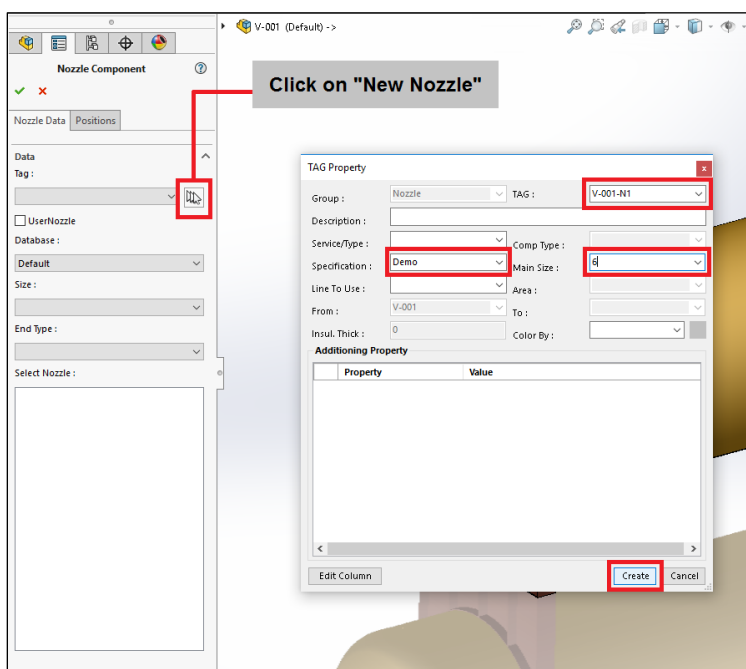

The **Nozzle Component** task pane is updated with the new tag and it will list in the dropdown menu **Tag**.

9. **Set the parameters of the nozzle.**

Select the values on the **Nozzle Component** task pane that are not yet defined.

- **End Type** dropdown menu: Select **FL** (Flange connection).
- **Selected Nozzle** list: Select **NON STANDARD 150LB FLAT FACE NOZZLE**.

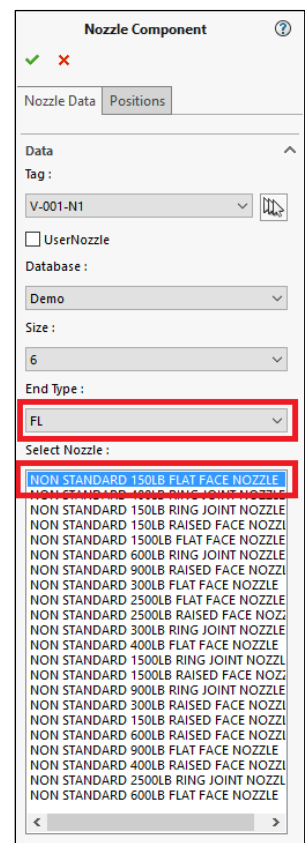

10. Click **Nozzle Component** pane > **Positions** tab.

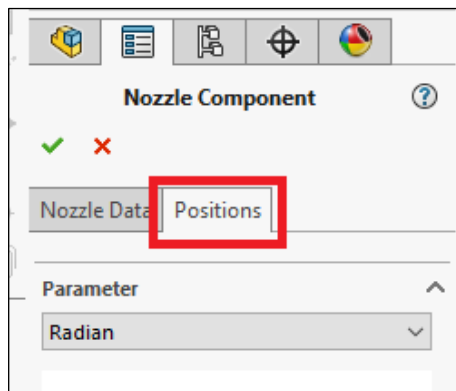

The task pane **Positions** is displayed for adding and controlling the position of the nozzle in the vessel.

The nozzle model can be placed in different types of surfaces and it is controlled from the dropdown menu **Parameter** on the **Positions** tab.

Parameter	Description
<b>Radian</b>	Circular surfaces
<b>Flat</b>	Flat surfaces
<b>Coordinate</b>	Point references and circular edges
<b>Line</b>	Along a line sketch entity
<b>Head</b>	Dome surface

By selecting any of the parameters from the **Parameter** menu, the **Positions** pane dynamically updates based on the parameter the user wants to access, displaying the fields and commands accordingly.

11. Select **Parameter** menu > **Radian**.

12. **Place the nozzle in the vessel.**

Click on any part of the circular body of the vessel, and the nozzle will be automatically inserted.



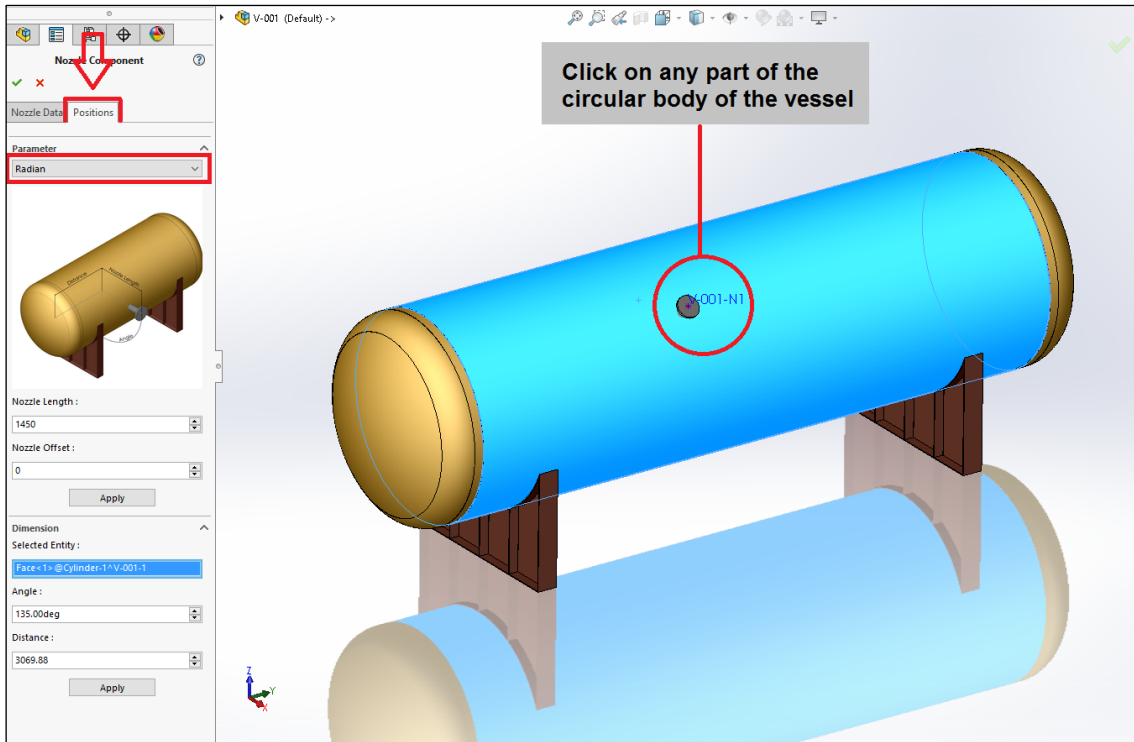

13. On the **Dimension** area on **Position** tab, set the parameters:

- **Angle** field: Type **360**.
- **Distance** field: Type **4000**.

14. Click **Apply** to update the position of the nozzle.

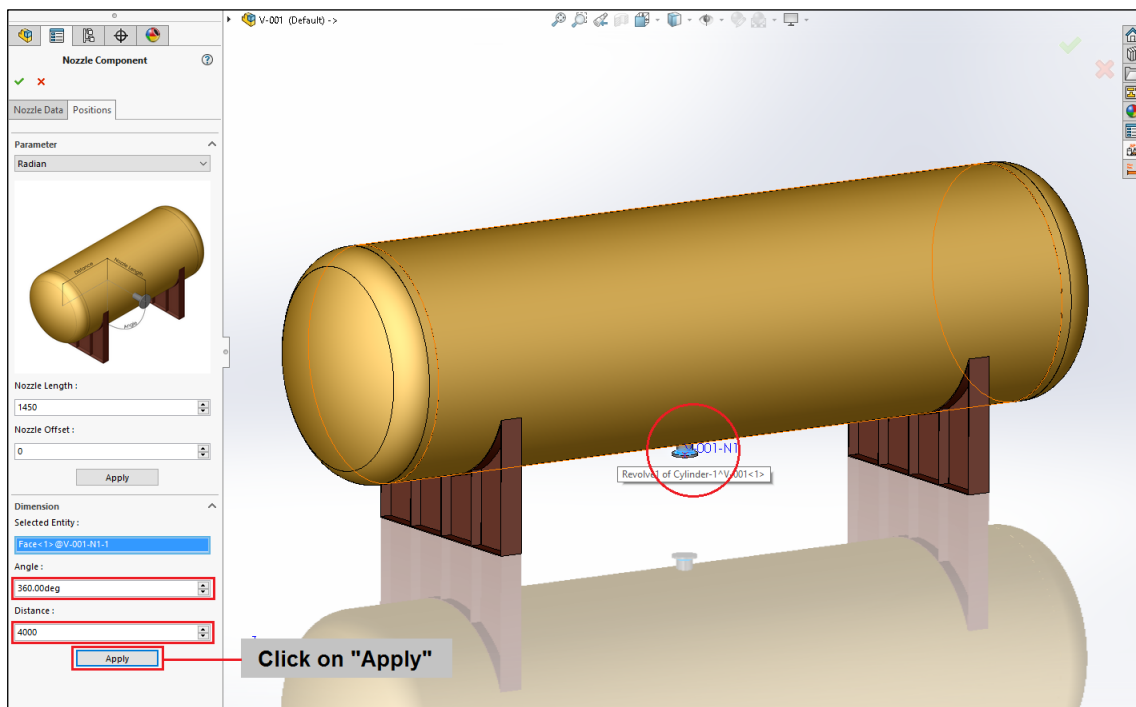



15. Do the same for **V-001-N2** nozzle with the same values as **V-001-N1** on **Nozzle Data** tab. On the **Dimension** area on **Position** tab, set the parameters on below:

- **Angle** field: Type **360**.
- **Distance** field: Type **5000**.

16. Click **Ok**  when finished.

17. **Save** on **Standard** toolbar.

18. **Close** the vessel assembly.

Back to the project, on the **Document List** node tree is displayed the tag **V-001**.

19. Click **Refresh**  if the tag is not displayed.

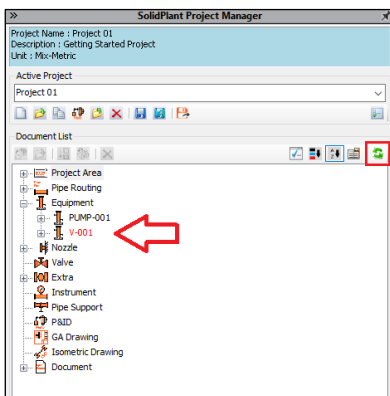

20. Click on the tag **V-001** on the **Document List** node tree and click **SolidPlant Project Manager** task pane > **Insert component to model**  .

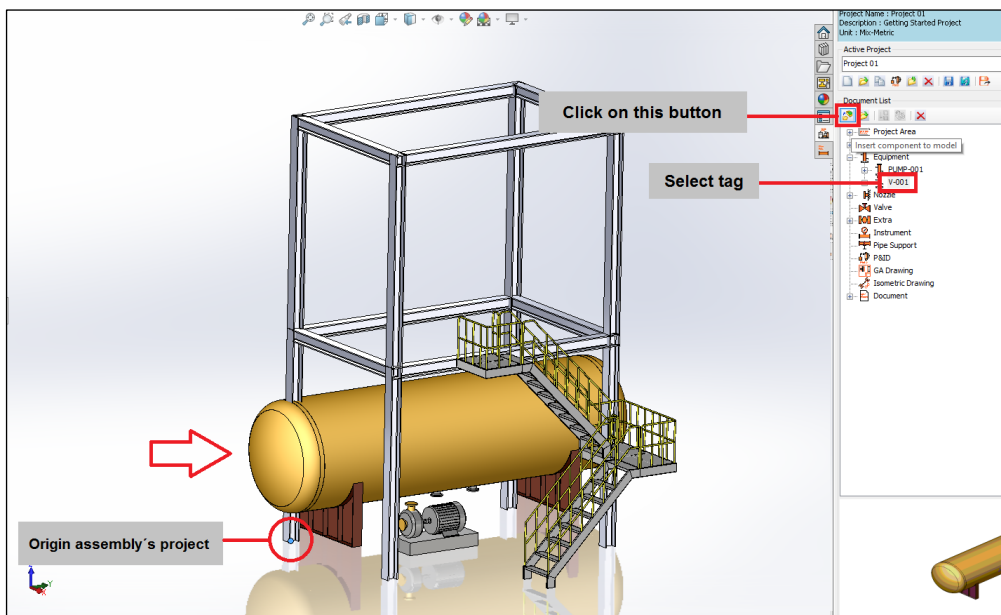

The vessel is placed automatically on the origin point of the project assembly.



21. Place the vessel at the top of the structure using SOLIDWORKS mates.

22. Click **Refresh**  to update the status of the tag **V-001** on the node tree.

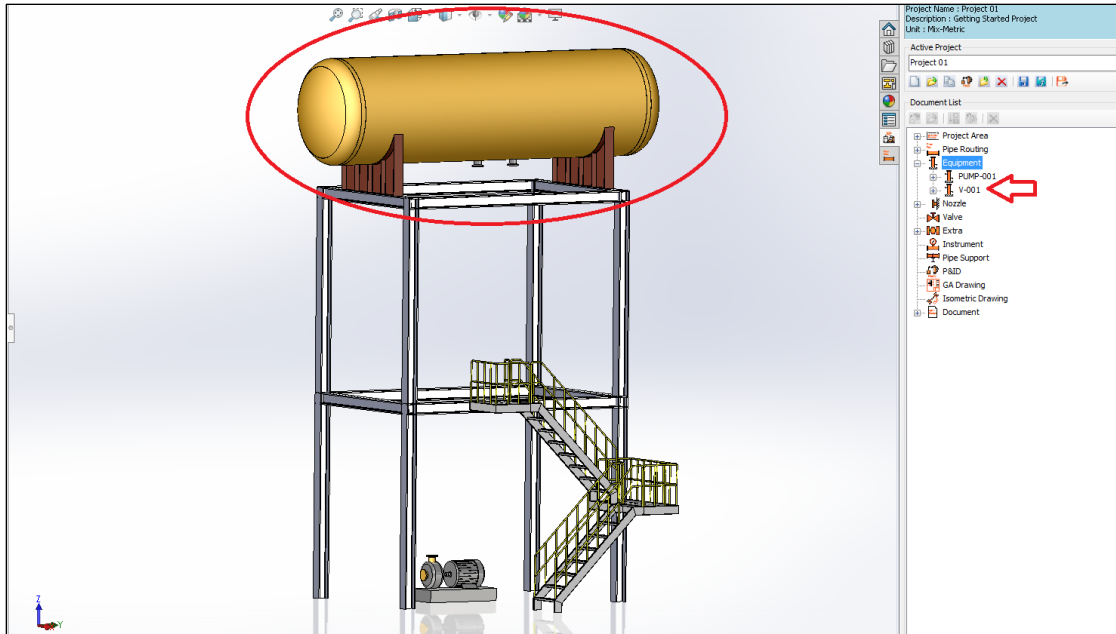

23. Click **Save** on **Standard** toolbar.

## Routing

SolidPlant 3D provides the necessary tools to create intelligent pipe routes driven by a piping specification. Depending on the piping components in the piping specification assigned to the pipe line in use, the components will be generated automatically from the route that has been created.

The routing features are mainly located in the **Routing** and **Component** tabs, and in the side task pane **SolidPlant Pipe Routing**.

### Creating a pipe line

In SolidPlant the pipe routes are special subassemblies of SOLIDWORKS that build a path of pipes, tubes or ducts with their piping components based on a 3D sketch of the center line of the route.

When you create a route with SolidPlant 3D, a route subassembly is created into the assembly project. The tag assigned to the route is the name of the subassembly. Unlike other types of subassemblies of SOLIDWORKS, you do not create a route assembly in its own window and then insert it as a component in the higher-level assembly.

SolidPlant uses functionality available in SOLIDWORKS and the user needs to be familiar with 3D sketching, assemblies, top-down design and mates, in order to become proficient.



SolidPlant 3D is a database driven system and the piping specifications assigned to the route will define the components generated into the pipe subassembly. SolidPlant 3D doesn't use libraries or configurations in routing, so that the user doesn't need to care about preparing the 3D components before designing. All the information is contained into the piping specification list.

The piping specification list or pipe class is a collection of most compatible components considering dimensional and material properties for the intended service over a range on pressure and temperature specified. It is a list for use within its confines and which contains the definition of pipe and all related components.

SolidPlant 3D comes with **SpecCreator** that is the application to build up the piping specification list based on a huge range of catalogues of components. These catalogues contain most of the standards of the industry (ANSI-ASME, DIN, JIS, etc.) as well as a wide range of manufacturers (Swagelok, Bonney Forge, George Fisher, etc.). We won't cover in this document this application so that the user will use the piping specification **Demo** that automatically is assigned by default to any newly created project.

There are three methods to route a line with SolidPlant 3D. In this document we will learn how to use two of them, **Manual Route** and **Auto Route**.

Method	Description
<b>Manual Route</b>	The user manually sketch the path of the pipe line
<b>Auto Route</b>	Automatic generation of the pipe line path based on the selection of two reference points (e.g. From Nozzle, To Nozzle)
<b>Smart Route</b>	Automatic generation of the pipe line based on the information imported from a P&ID or .xls file into the database of the project

## Manual Route method

To create a pipe route:

1. Click **Routing Tab** > **Manual Route**.

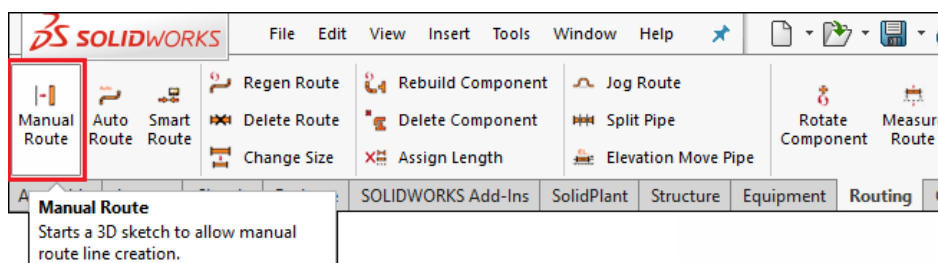

The **Tag property** dialog box will display in order to define the parameters of the pipe route.

As the user has already realized, the **Tag property** dialog box is also used to define the properties of the equipment and their nozzles.



Field	Description
<b>Group</b>	Displays the type of the component
<b>TAG</b>	Unique piping identification
<b>Description</b>	Extra information to describe the route
<b>Service/Type</b>	Types of fluids. You can select from the dropdown menu or type a value
<b>Specification</b>	Dropdown menu listing the piping specifications available in the project
<b>Main Size</b>	Dropdown menu listing the sizes available from the selected piping specification
<b>Line To Use</b>	Disabled in pipe routing. It is used to assign a component to a pipe line
<b>Area</b>	Dropdown menu listing the areas available in which a pipe line can be grouped
<b>From</b>	Dropdown menu listing all the lines, equipment and equipment nozzle tags available where the pipe starts
<b>To</b>	Dropdown menu listing all the lines, equipment and equipment nozzle tags available where the pipe ends
<b>Insul. Thick</b>	Insulation thickness. You can type a number in millimeters
<b>Color By</b>	Dropdown menu listing the different ways to define the color of the pipe line
<b>Additioning Property</b>	A collection of fields available for adding further information to the pipe line which can be extended by the user

2. From the window **TAG Property**:

- **Tag** field: Type **PIP-001**
- **Specification** dropdown menu: Select **Demo**.
- **Description** field: Type **Getting Started Pipe 001** (Optional).
- **Main Size** dropdown menu: Select **6** inches.

3. Click **Create**.

The screenshot shows the 'TAG Property' dialog box with the following settings:



- Group:** Pipe Routing
- TAG:** PIP-001
- Description:** Getting Start Pipe 001
- Service/Type:** (empty)
- Comp Type:** (empty)
- Specification:** Demo
- Main Size:** 6
- Line To Use:** (empty)
- Area:** (empty)
- From:** (empty)
- To:** (empty)
- Insul. Thick:** 0
- Color By:** (empty)

The 'Adding Property' section contains a table with the following properties:

Property	Value
MATERIAL	
SCHEDULE	
RATING	
REVISION	
PAINTING_SPEC	
PIPELINE_TEMP	
TRACING_SPEC	
SURFACE_AREA	
PIPELINE_TYPE	

Buttons at the bottom include 'Edit Column', 'Create', and 'Cancel'.



On creating the pipe line the user is automatically on **3D Sketch** mode  and the tool **Line**  is active. On the FeatureManager of SOLIDWORKS, the subassembly **PIP-001** with the name of the tag is created and the sketch line of the route will be active, 3DSketch1.

The pipe subassembly contains two folders, **Pipe** and **Component** where it will store the piping components.

Folder	Description
<b>Pipe</b>	Contains the parts of the pipe sections of the route
<b>Component</b>	Contains the component parts of the route (Flanges, valves, elbows, etc.)

 Once a line is sketched, the 3DSketch1 will be renamed to **Main**. If a line is not created, the **3D Sketch** won't be created.

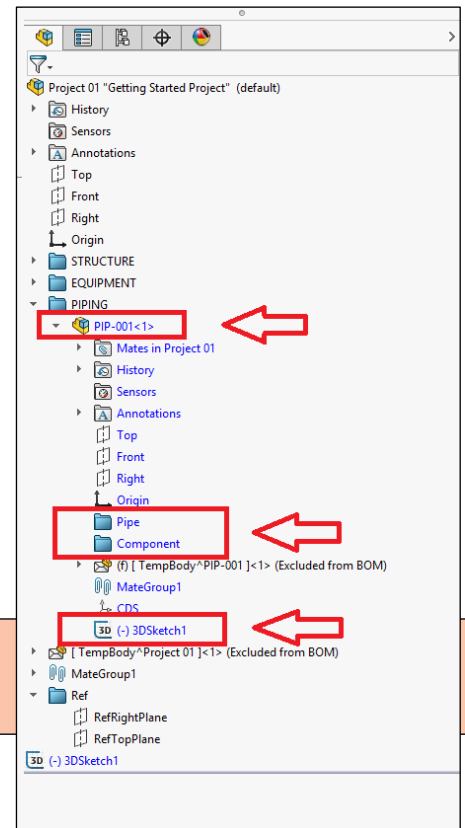

4. **Hide** the folder **Structure** for better performance and clearer environment.

5. **Sketch a line.**

Sketch a line vertically along Z axis from the reference point of the nozzle pump **PUMP-001-N2**. The length is not important.

A preview of a pipe will display along the line to highlight the route.

6. Right-click in the graphic area and select **Select** from the shortcut menu to confirm the line.

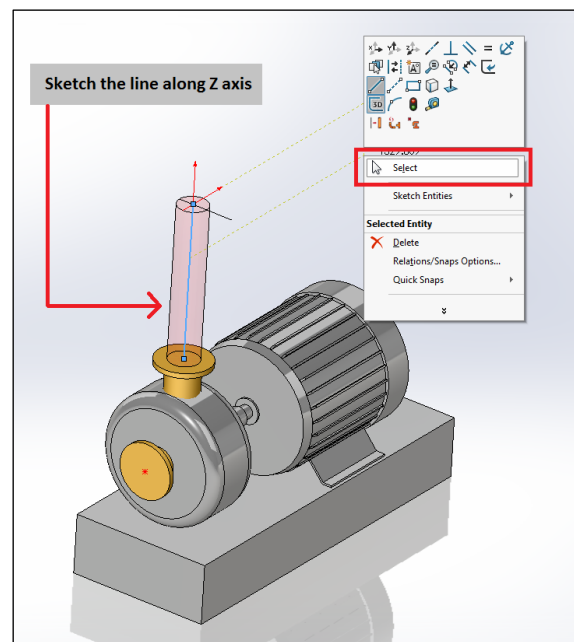

SolidPlant 3D will display the **Select Component** window listing all the components available in the piping specification **Demo** for the current size of the pipe line, which is **6** inches. The user can select the components according to his needs for the referring pipe.

SolidPlant 3D is an intelligent system and it recognizes the nozzle point connection so that it will display the **Select Component** window for the needed components depending on the properties of the nozzle (Flange, gasket and bolts).

## 7. Select a pipe component.

When prompted, select the pipe component available from the **Demo** piping specification from **6** inches size. Select the component shown on the picture below and click **Create**.

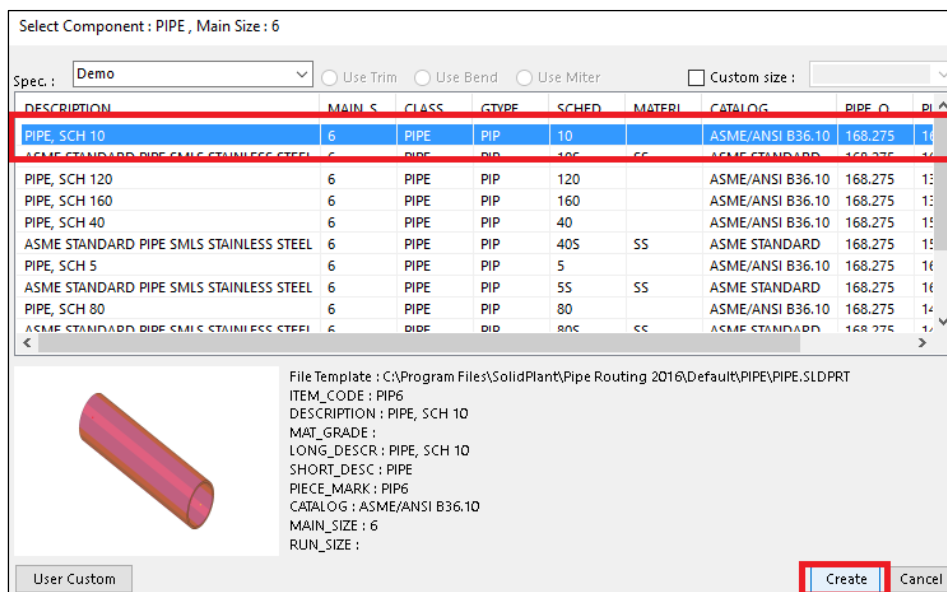

## 8. Select a flange component.

When prompted, select the flange component shown on the picture below and click **Create**.

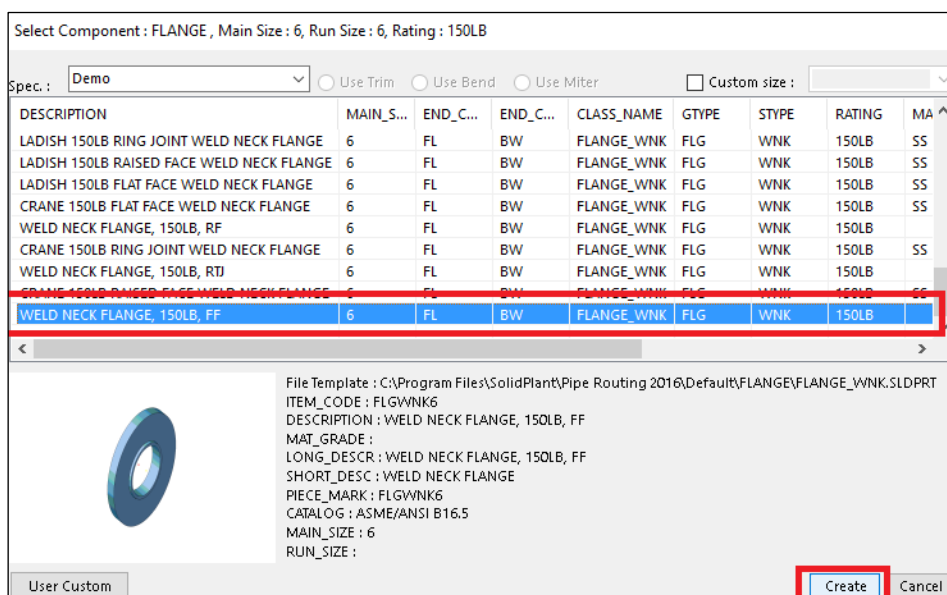

## 9. Select a gasket component.

When prompted, select the component shown on the picture below and click **Create**.

Select Component : GASKET , Main Size : 6, Rating : 150LB

Spec.: Demo  Use Trim  Use Bend  Use Miter  Custom size :

DESCRIPTION	MAIN_S...	END_C...	CLASS...	GTYPE	RATING	MATERI...	CATAL...
ASME STANDARD 150LB R-43 RING OCTAGONAL GASKET	6	FL	GASKET	GAS	150LB	SS	ASME
ASME STANDARD 150LB RAISED FACE NONMETALIC GASKET	6	FL	GASKET	GAS	150LB	NEO	ASME
ASME STANDARD 150LB RAISED FACE SPIRAL WOUND GASKET	6	FL	GASKET	GAS	150LB	SS	ASME
<b>GASKET, 150LB</b>	<b>6</b>	<b>FL</b>	<b>GASKET</b>	<b>GAS</b>	<b>150LB</b>	<b>SS</b>	<b>ASME</b>
GASKET, 150LB	6	FL	GASKET	GAS	150LB	SS	ASME
ASME STANDARD 150LB FLAT FACE NONMETALIC GASKET	6	FL	GASKET	GAS	150LB	NEO	ASME
ASME STANDARD 150LB FLAT FACE JACKETED GASKET	6	FL	GASKET	GAS	150LB	SS	ASME
ASME STANDARD 150LB RAISED FACE JACKETED GASKET	6	FL	GASKET	GAS	150LB	SS	ASME
GASKET, 150LB, NEO	6	FL	GASKET	GAS	150LB	NEO	ASME
GASKET, 150LB	6	FL	GASKET	GAS	150LB	SS	ASME

File Template : C:\Program Files\SolidPlant\Pipe Routing 2016\Default\GASKET\GASKET.SLDPRT  
ITEM\_CODE : GAS6  
DESCRIPTION : GASKET, 150LB  
MAT\_GRADE :  
LONG\_DESCR : GASKET, 150LB  
SHORT\_DESCR : GASKET  
PIECE\_MARK : GAS6  
CATALOG : ASME/ANSI B16.20  
MAIN\_SIZE : 6  
RUN\_SIZE :

User Custom

## 10. Select bolts component.

When prompted, select the component shown on the next picture and click on **Create** button.

Select Component : BOLT , Main Size : 6, Rating : 150LB, Bolt Length : 53.975

Spec.: Demo  Use Trim  Use Bend  Use Miter  Custom size :

DESCRIPTION	MAIN_S...	CLASS...	GTYPE	STYPE	RATING	MATERI...	CATALOG	FAC...
<b>ASME STANDARD, 3/4 X 105 STUD BOLT</b>	<b>6</b>	<b>BOLT</b>	<b>BOLT</b>		<b>150LB</b>	<b>SS</b>	<b>ASME STANDARD</b>	<b>FF</b>
ASME STANDARD, 3/4 X 115 STUD BOLT	6	BOLT	BOLT		150LB	SS	ASME STANDARD	RTJ
ASME STANDARD, 3/4 X 105 STUD BOLT	6	BOLT	BOLT		150LB	SS	ASME STANDARD	RF
ASTM A307, 3/4 X 115 STUD BOLT	6	BOLT	BOLT		150LB		ASTM A307	RTJ
ASTM A307, 3/4 X 105 STUD BOLT	6	BOLT	BOLT		150LB		ASTM A307	FF
ASTM A307, 3/4 X 105 STUD BOLT	6	BOLT	BOLT		150LB		ASTM A307	RF
ASME STANDARD, 3/4 X 100 MACHINE BOLT	6	LUG_BOLT	BOLT	LUG	150LB	SS	ASME STANDARD	RTJ
ASME STANDARD, 3/4 X 85 MACHINE BOLT	6	LUG_BOLT	BOLT	LUG	150LB	SS	ASME STANDARD	FF
ASME STANDARD, 3/4 X 85 MACHINE BOLT	6	LUG_BOLT	BOLT	LUG	150LB	SS	ASME STANDARD	RF
ASTM A307, 3/4 X 85 MACHINE BOLT	6	LUG_BOLT	BOLT	LUG	150LB		ASTM A307	FF

File Template : C:\Program Files\SolidPlant\Pipe Routing 2016\Default\BOLT\BOLT.SLDPRT  
ITEM\_CODE : BOLT6  
DESCRIPTION : ASME STANDARD, 3/4 X 105 STUD BOLT  
MAT\_GRADE :  
LONG\_DESCR : ASME STANDARD, 3/4 X 105 STUD BOLT  
SHORT\_DESCR : STUD BOLT  
PIECE\_MARK : BOLT6  
CATALOG : ASME STANDARD  
MAIN\_SIZE : 6  
RUN\_SIZE :

User Custom



Double-click on the selected component in the **Select Component** window will also confirm the component instead of clicking **Create** button.



The pipe line will be created with all the piping components added automatically. On the FeatureManager on the left hand side, the pipe section parts will be contained into the `Pipe` folder, and the rest of the piping component parts will be on the `Component` folder.

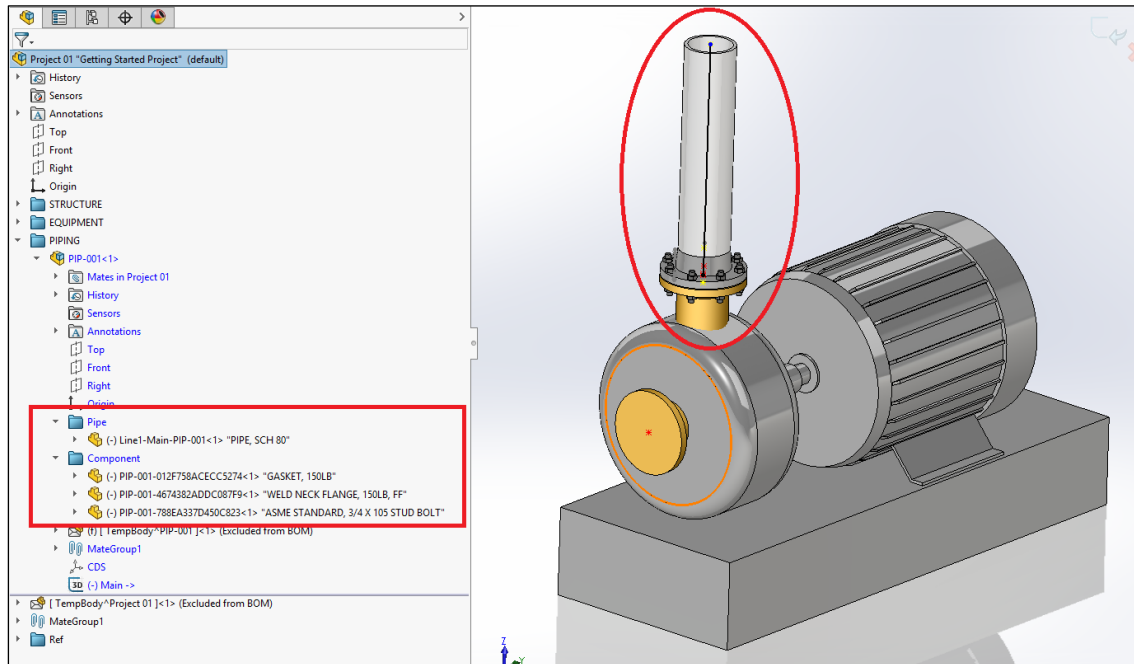

The user can mark and enable the check box **Disable Routing Mode** in the **SolidPlant Pipe Routing** task pane, in order to disable the automatic generation of the 3D piping components, so that the user can easily draw the path without any interferences.

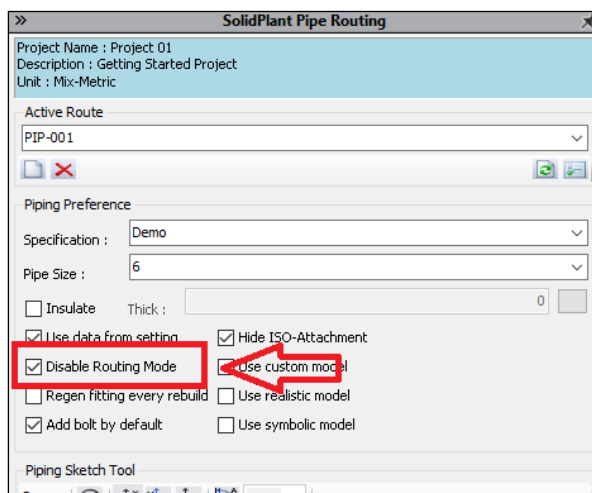

**11.** Mark the check box **Disable Routing Mode** on the **SolidPlant Pipe Routing** pane.





12. On the CommandManager, click **Sketch** tab > **Line** .

13. **Sketch a line.**

Sketch a path from the end point of the previous pipe line and draw a path as shown on picture below. The length is not important.

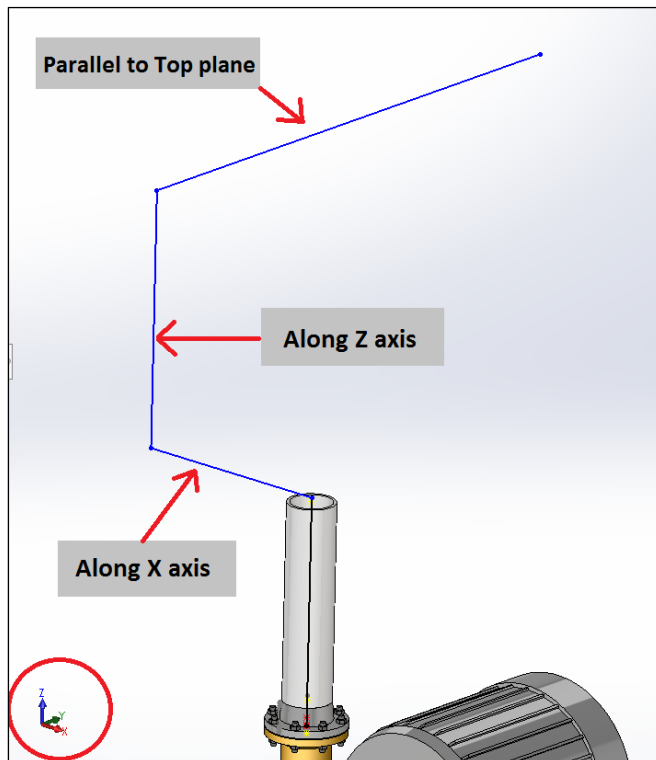

14. Uncheck **SolidPlant Pipe Routing** > **Piping Reference** > **Disable Routing Mode**.

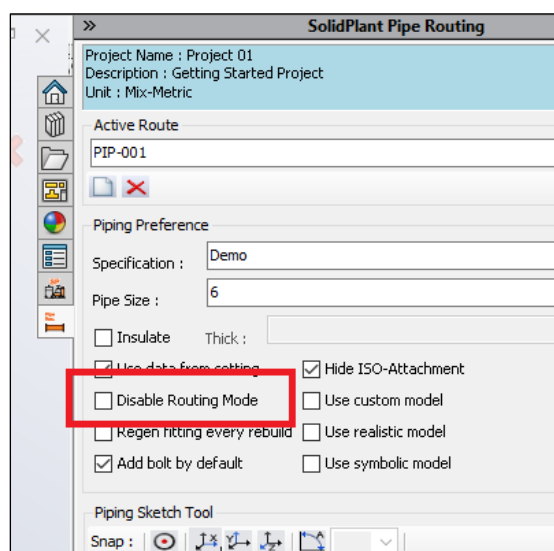

Now the automatic generation of the piping components is enabled again for generating the rest of the route.



## 15. Select elbow component.

When prompted, select the component shown on the next picture and click **Create**.

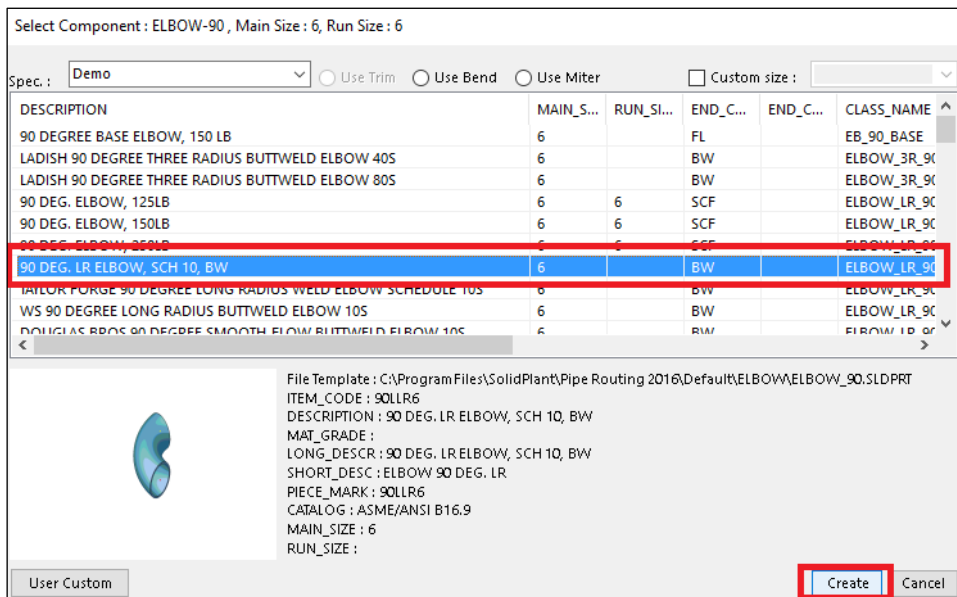

SolidPlant 3D is sensitive of the path that is routed by the user.

It recognizes that on the point connection between two perpendicular lines a 90 degrees elbow is required.

Therefore it will display the **Select Component** window for the missing components and it will automatically generate the rest of the components that were used previously.

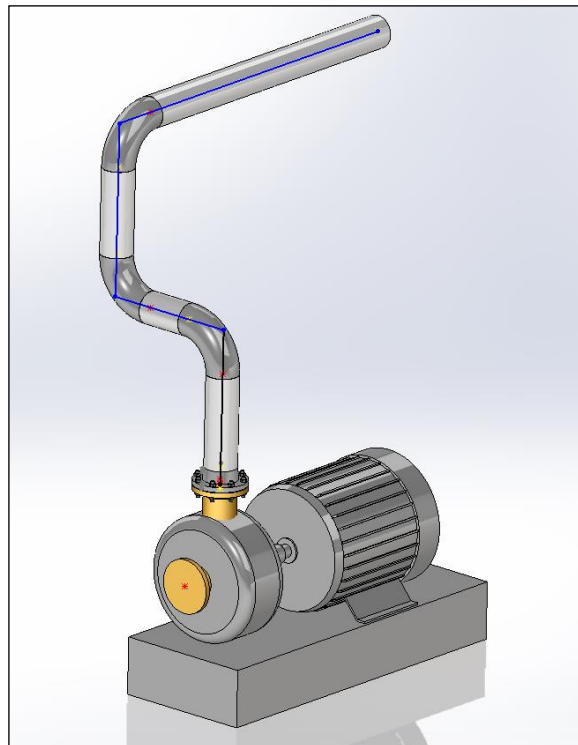

16. Mark **SolidPlant Pipe Routing > Piping Reference > Disable Routing Mode** check box.

17. On the CommandManager, click **Sketch** tab > **Line** .

18. **Sketch a line.**

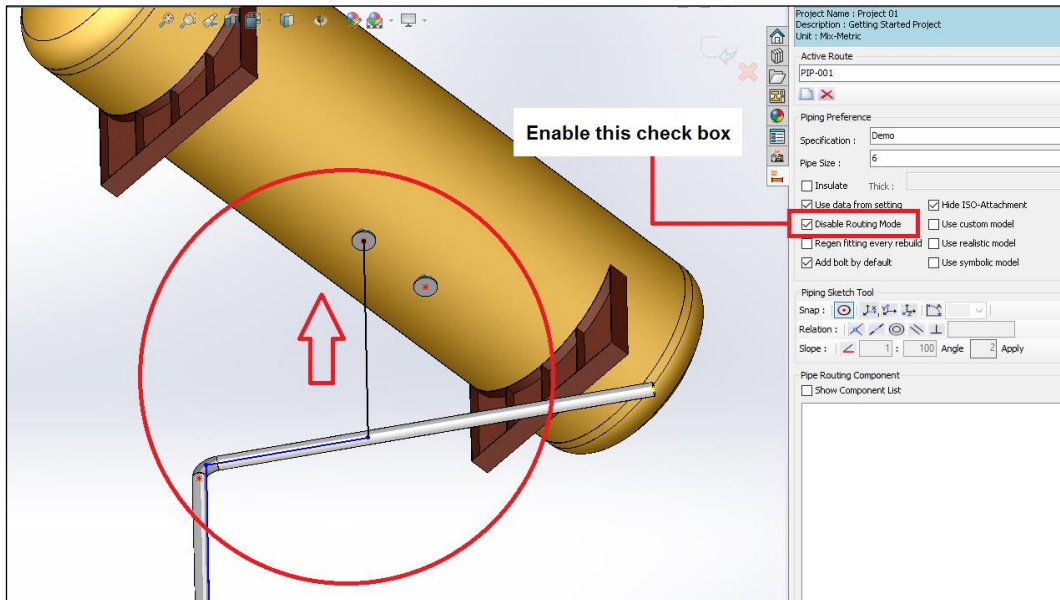

From the end point of the pipe line, sketch a line vertically along Z axis up to the vessel nozzle **V-001-N1**.

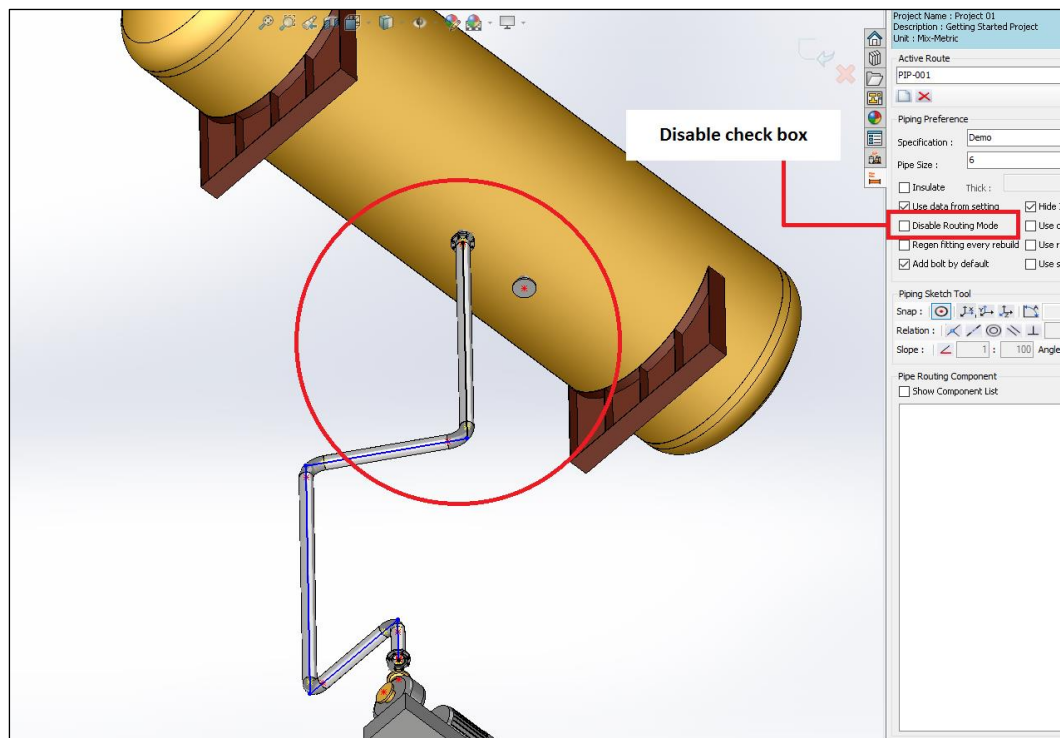

19. Uncheck **SolidPlant Pipe Routing > Piping Reference > Disable Routing Mode**.



SolidPlant 3D will generate all the piping components of the route with the same components used previously.

 If any line of the path is toggled **For construction** in the PropertyManager, SolidPlant 3D will remove the pipe section as it doesn't recognize **Centerlines**  as part of the pipe path. The user will be able to use the **Centerline** tool for referencing purposes.

20. Exit from **3D Sketch** mode.

21. Exit from **Edit Assembly** mode.

22. **Save** on **Standard** toolbar.

## Auto Route method

To create a pipe route:

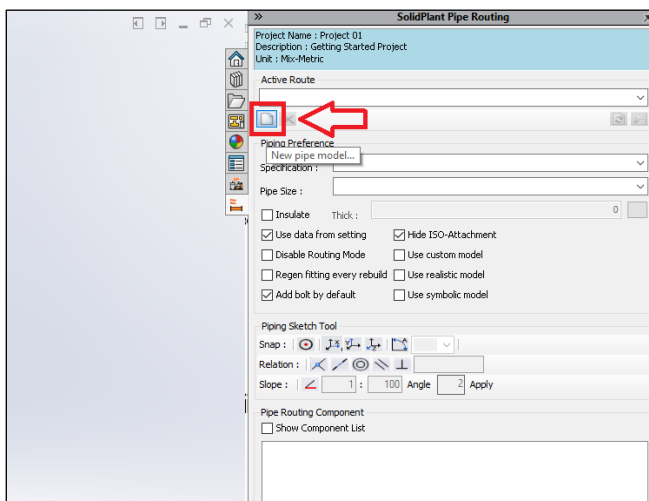

1. Click **SolidPlant Pipe Routing Pane > New pipe model**



2. From the window **TAG Property**:

- **Tag** field: Type **PIP-002**
- **Specification** dropdown menu: Select **Demo**.
- **Description** field: **Getting Started Pipe 001** (Optional).
- **Size** dropdown menu: Select **6** inches.

3. Click **Create**.

On creating the pipe line the user is automatically on **3D Sketch** mode  and the tool **Line**  is active.



4. Click **Routing Tab > Auto Route**.

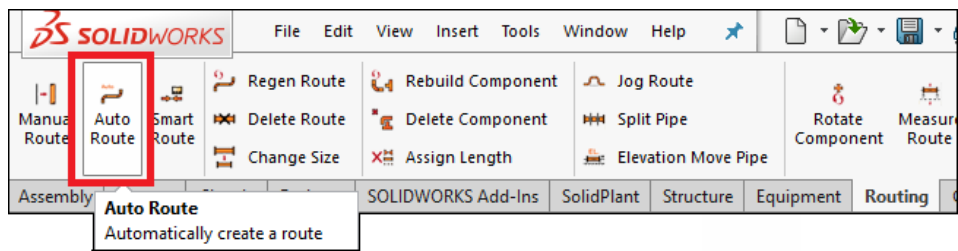

The task pane **Auto Route Line** is displayed on the left hand side on the PropertyManager.

5. Select the edge of the pump nozzle **PUMP-001-N1**.

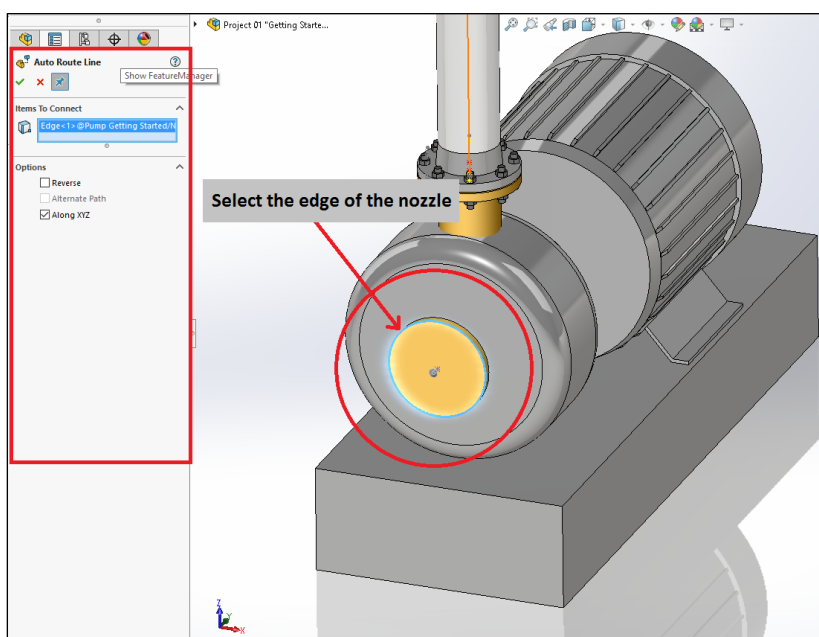

6. Select the edge of the vessel nozzle **V-001-N2**.

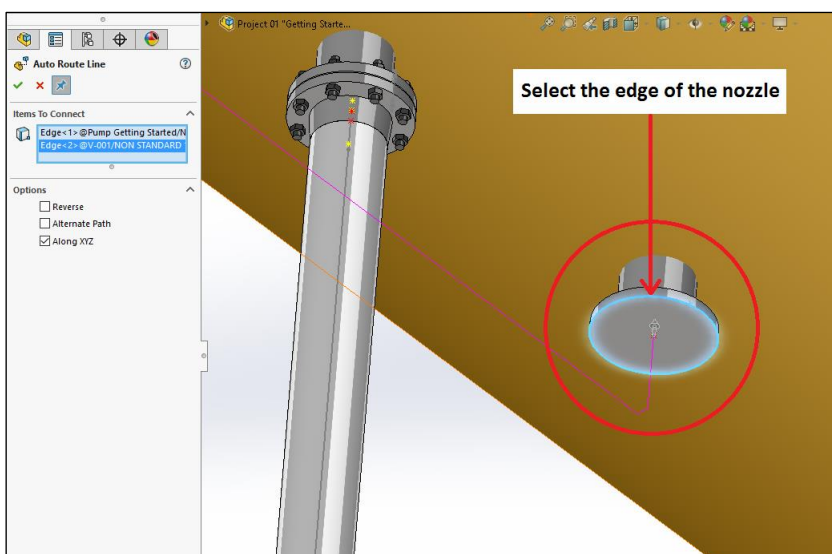

A preview of the path between the two nozzles is displayed. Along the path are available arrows to alternate the direction of the current route.

7. Click just once **Auto Route Line** pane > **Ok**  when the path is finished.

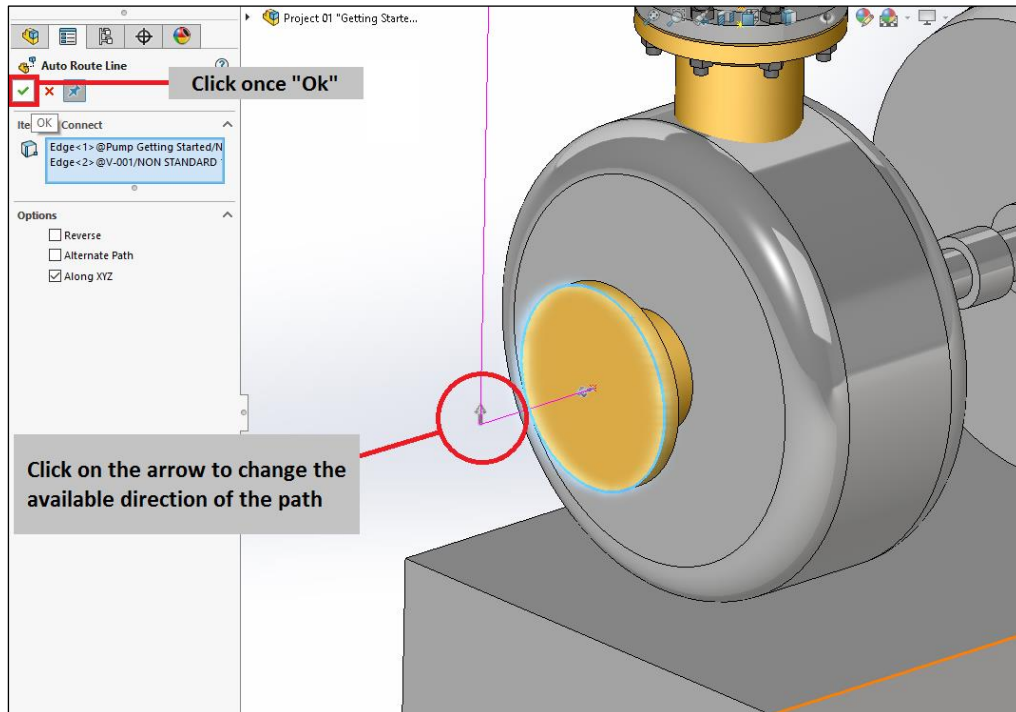

8. Mark the check box **Disable Routing Mode** on the **SolidPlant Pip Routing** pane.

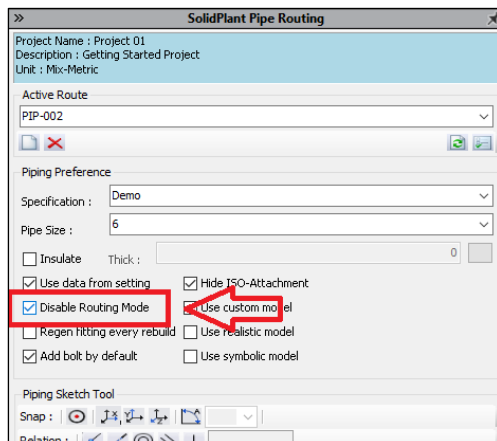

9. Click **Auto Route Line** pane > **Ok**  .

The user can change the route by adding or deleting new lines without generating the 3D piping components.



## 10. Sketch a line.

Sketch the path as shown on below picture to avoid the existing pipe **PIP-001**, by adding or deleting the necessary lines.

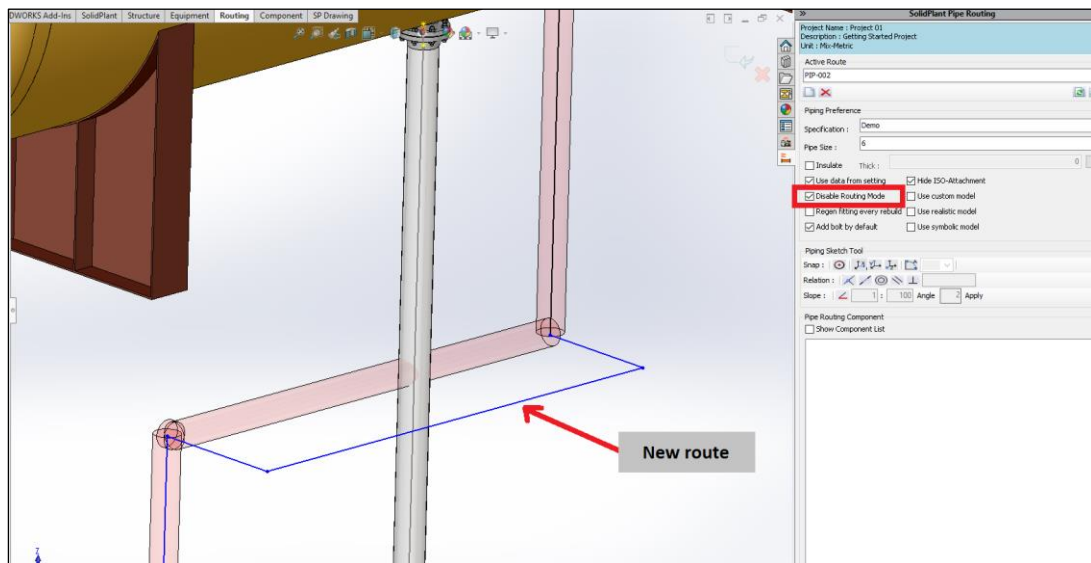

## 11. Uncheck SolidPlant Pipe Routing > Piping Reference > Disable Routing Mode.

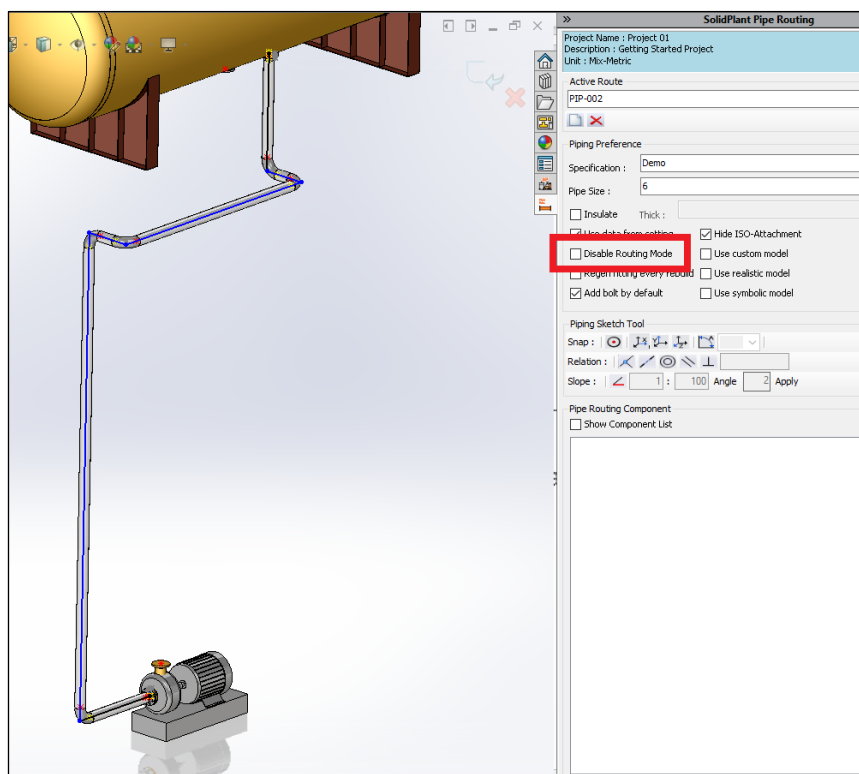

12. When prompted **Select Component** windows the user can select the same components as **PIP-001** for Pipe, Flange, Gasket, Bolt and Elbow.



13. Exit from **3D Sketch** mode.

14. Exit **Edit Assembly** mode.

15. **Save** the project.

## Adding components

### Valve component

**1. Make active the route.**

Right-click on the sketch line of **PIP-002** shown on picture below and select **Edit Sketch**  from the shortcut menu.

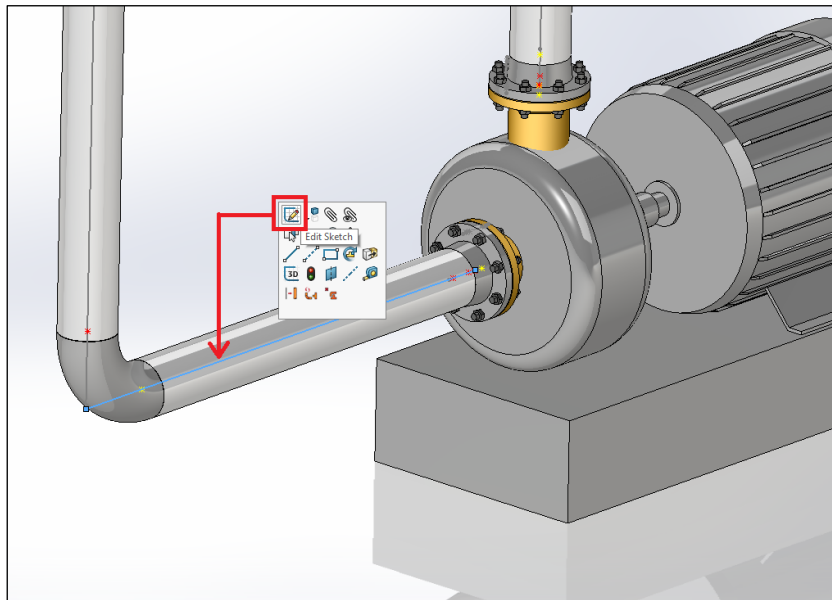

The route will be on **3D Sketch** mode ready to be edited.

**2.** Just click on any point of the sketch line (recommended around the middle).

**3.** Click **Component** Tab > **Valve**.

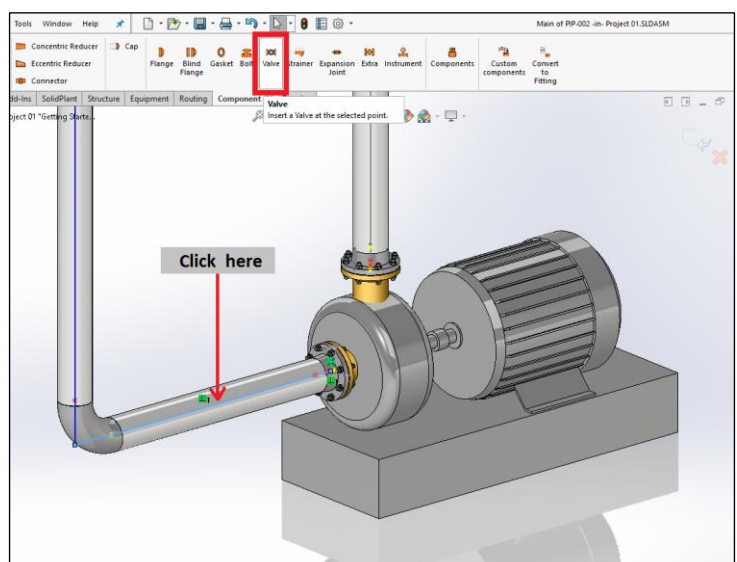



- When prompted, select **Selection Point** option and click **Apply**.

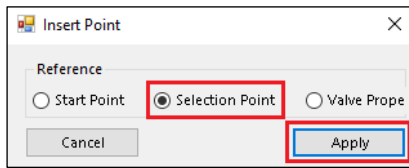

A point will be added where the user clicked on previously and it will be the middle reference point of the valve. The dialog box **Valve Property** will be displayed in order to define the tag of the valve.

- When prompted, type **VALV-001** on the **Tag** field.
- Click **Ok**.

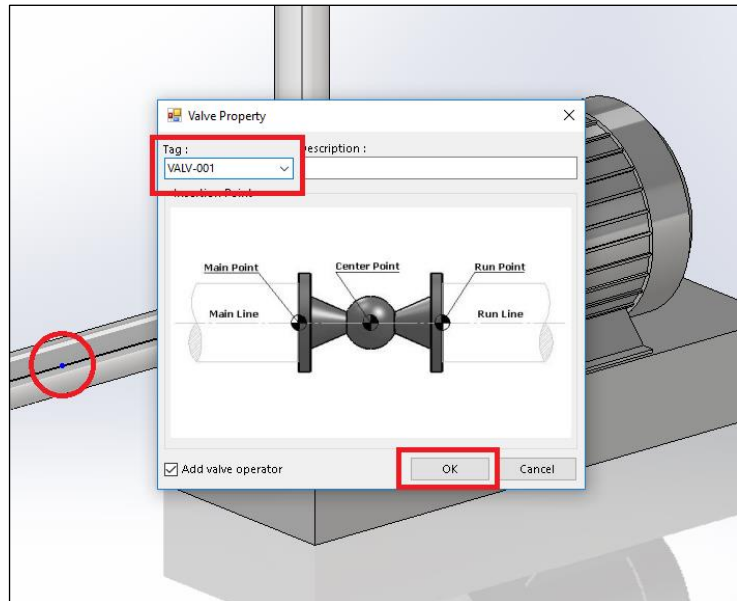

- Select valve component.**

When prompted, select the component shown on the next picture and click **Create**.

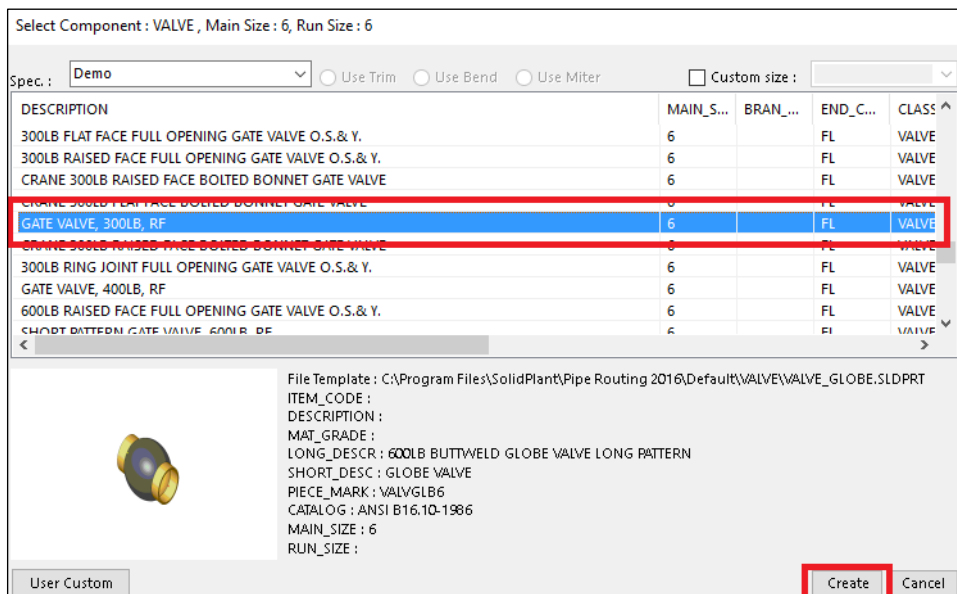

## 8. Select flange component.

When prompted, select the component shown on the next picture and click **Create**.

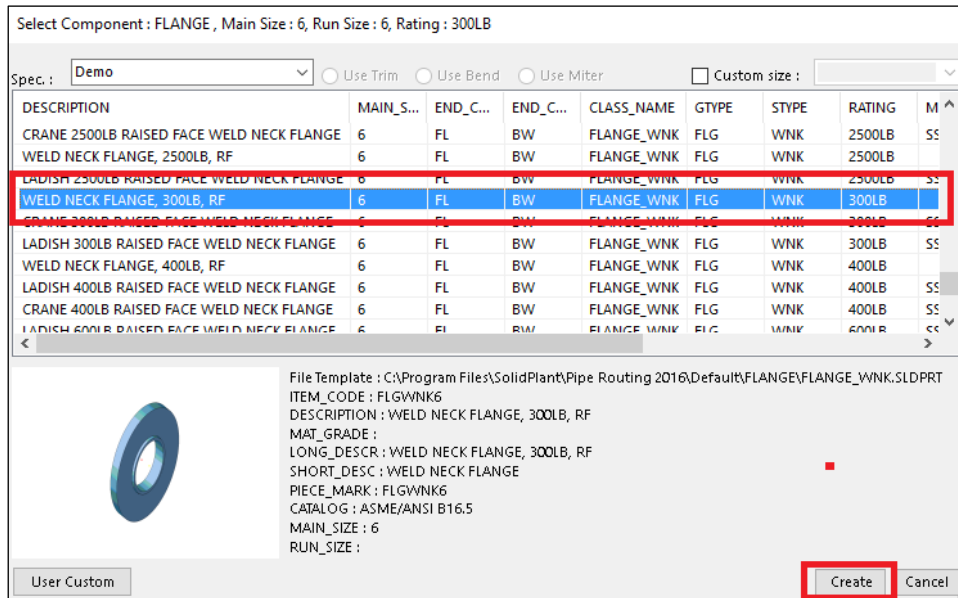

## 9. Select bolt component.

When prompted, select the component shown on the next picture and click **Create**.

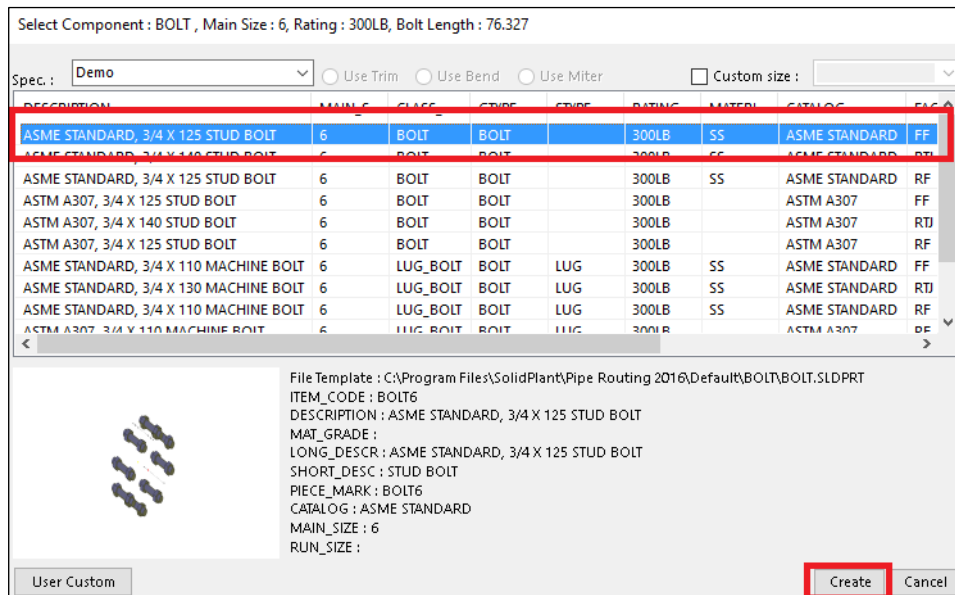

The valve is added automatically on the sketch line and its reference point is the middle point which has split the line into two sketch lines.



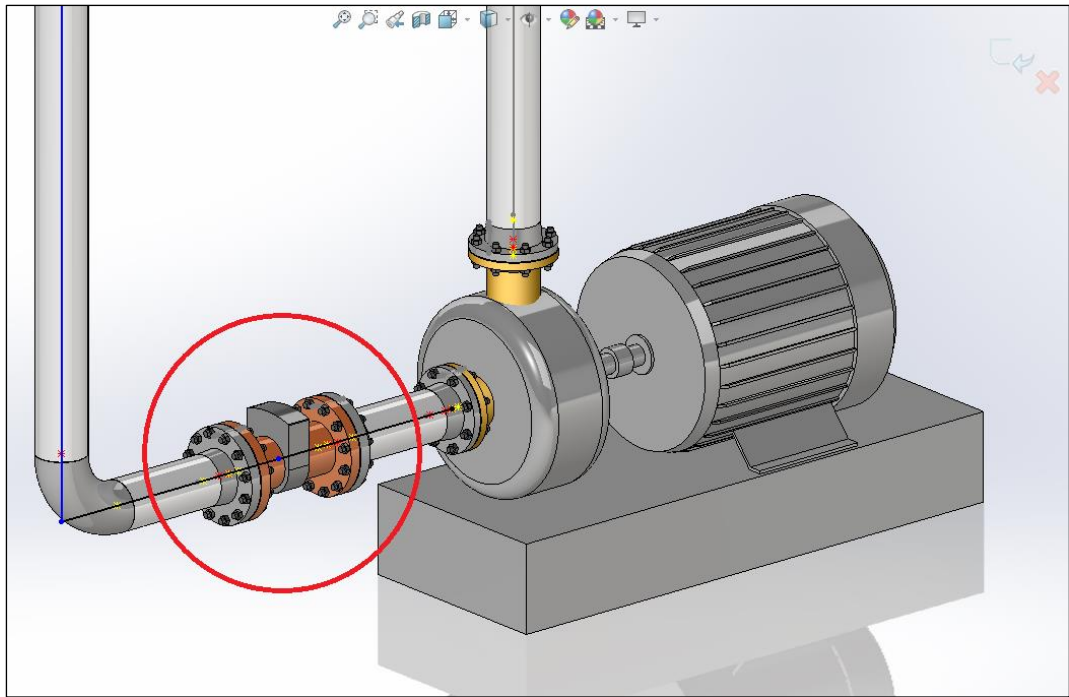

10. Select the sketch line highlighted on the picture below.

11. Click **Routing Tab > Assign Length**.

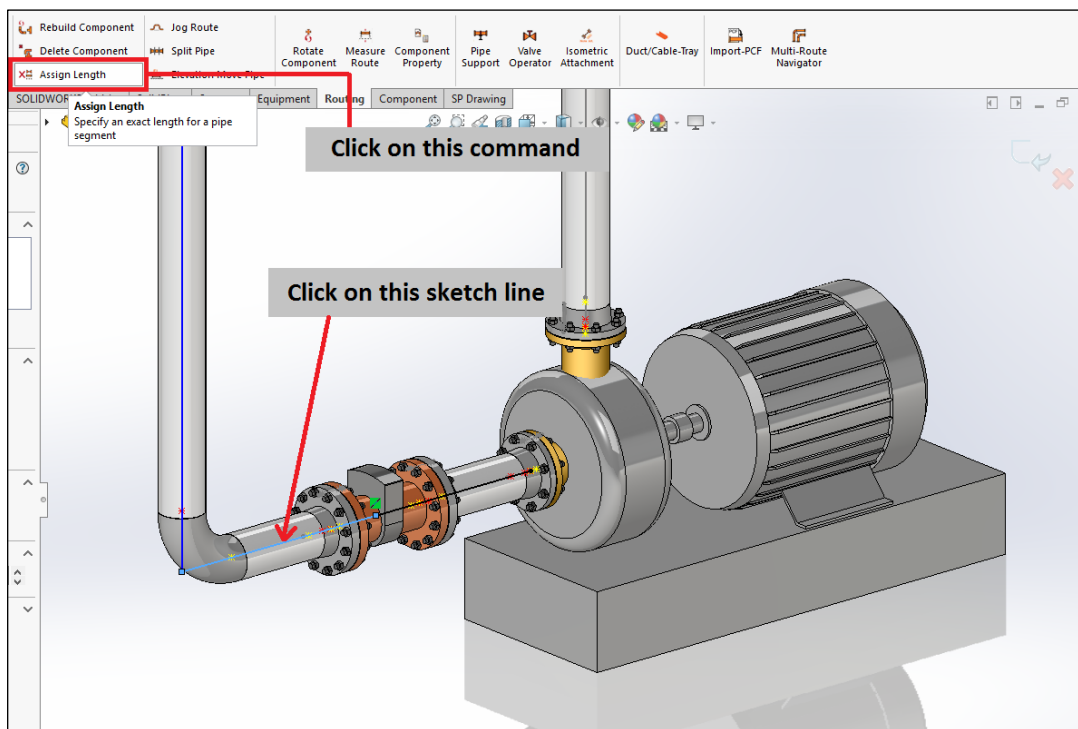

12. When prompted, type **500 mm** on field **Change pipe length to (mm)**.

13. Click **Apply**.

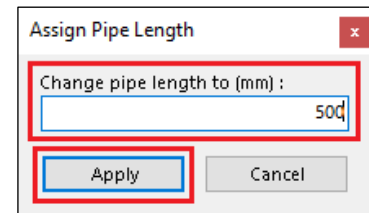

The pipe section will change to 500mm length automatically from the selected sketch line. The user doesn't need to calculate the dimension value to get the needed length for the section.

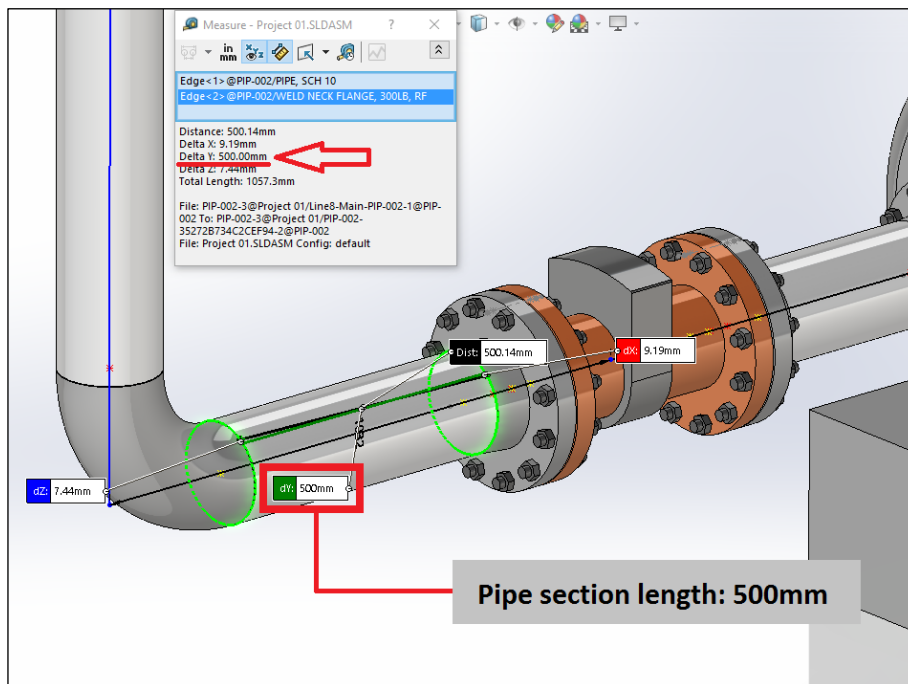

14. Exit from **3D Sketch** mode.

15. Exit **Edit Assembly** mode.

16. **Save** on **Standard** toolbar.

## Pipe Support component

1. Right-click on any sketch line of **PIP-002** and from the shortcut menu click **Edit Sketch**  to make the line active.



2. Click **Routing Tab > Pipe Support**.

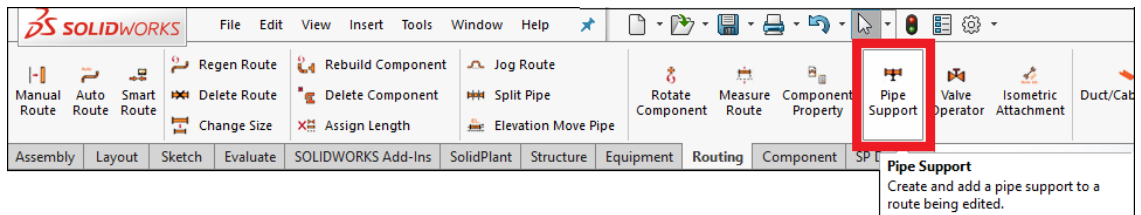

The window **Available Pipe Support** is displayed with the pipe supports available in the library of SolidPlant 3D.

3. Just click on any point of the sketch line (recommended around the middle).
4. Double-click on the icon **Pipe Support B** on the **Available Pipe Support** window.

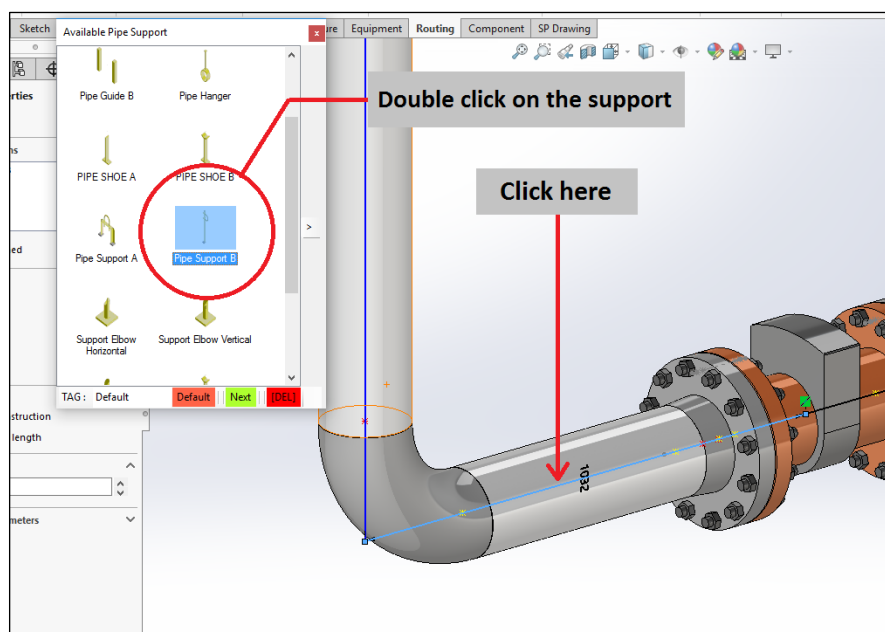

The pipe support is placed on the selected point on the pipe line. Notice that the support has been adjusted automatically to the outer diameter of the pipe.

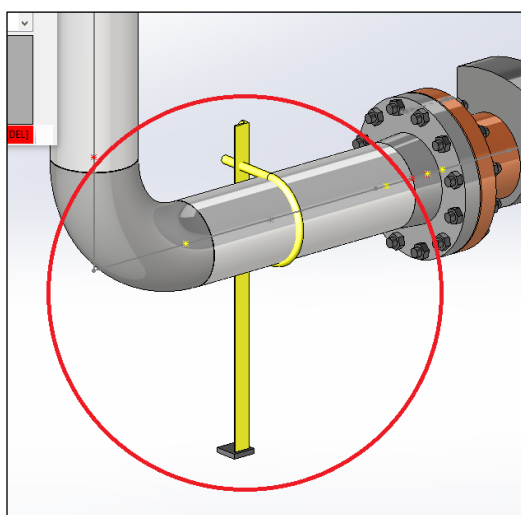

5. Click **Next** on the **Available Pipe Support** window.

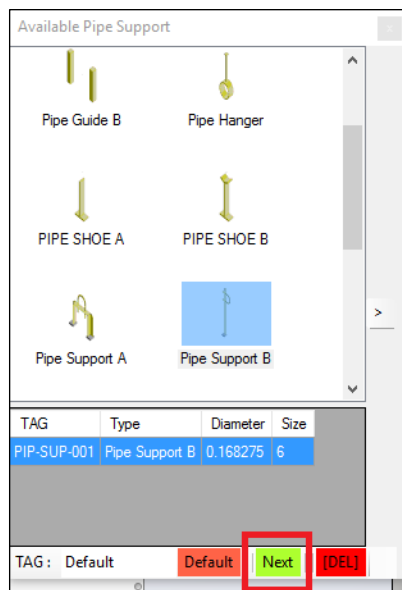

The **Editing Pipe Support** dialog box is displayed to set a number of parameters of the pipe support selected.

6. Set the dimension length.

- **Length** field: Type **650**.
- Click **Set**  .

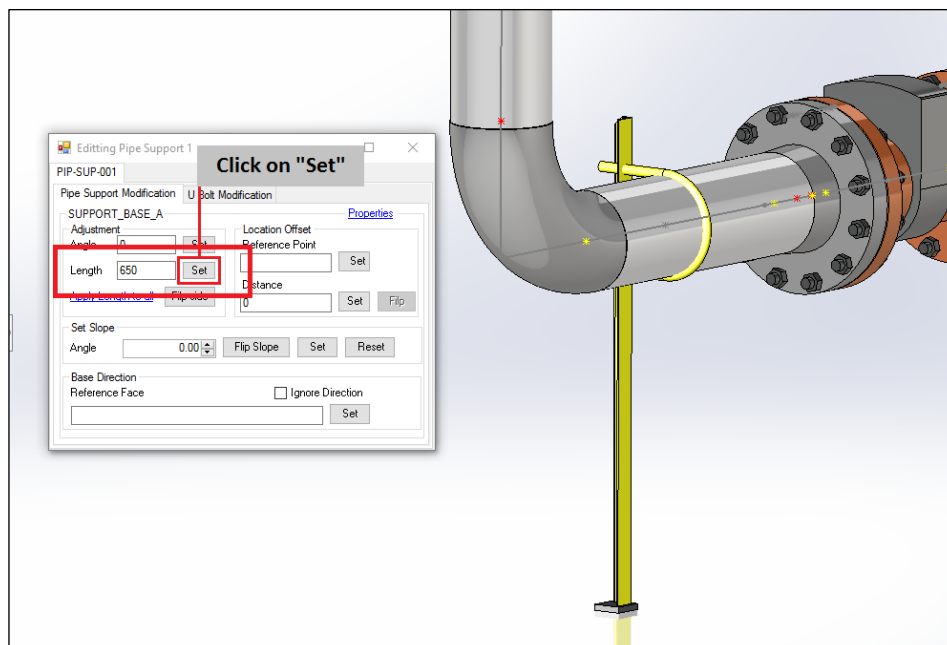

7. Close  **Editing Pipe Support** dialog box and then **Available Pipe Support** window.

8. **Save** on **Standard** toolbar.



SolidPlant 3D has embedded Isogen® from Alias for the total automation of piping isometric drawing production and is the de facto standard CAD system for drawing piping isometrics. The user will eliminate the need to manually edit isometric drawings which significantly reduces fabrication and on-site construction errors.

Also SolidPlant 3D provides the tools needed to create professional GA Drawings, Plane Sections, etc.

## Gen PCF command

1. Click **Drawing Tab > Gen PCF**.

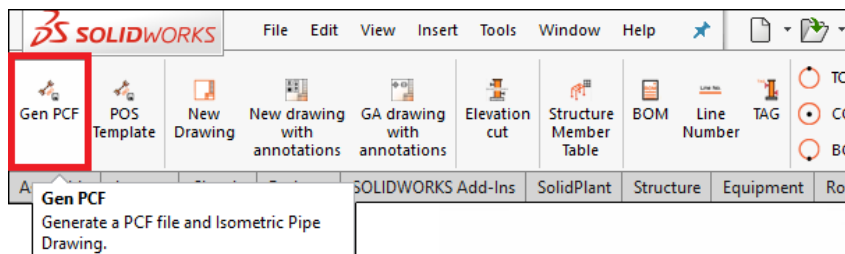

2. From the window **ISOGen** will be listed all the pipe lines created on the project.

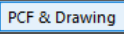
- Select the check box **PIP-002** from the list.
- From the **Drawing Style** dropdown menu: Select **Final-Cut-List**.
- Click **PCF & Drawing** .

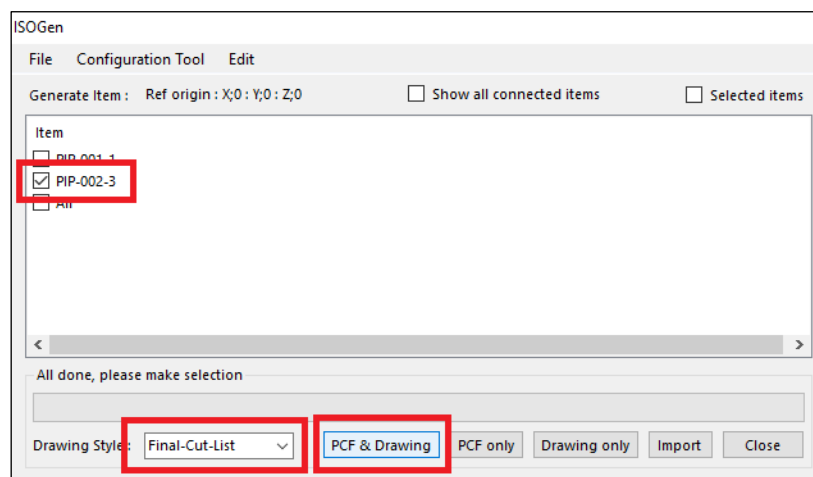

---

SolidPlant 3D will generate three different types of documents from the pipe line selected.



Type	Description
<b>PCF</b>	The Piping Component File is the primary input for personal ISOGEN. PCFs are text files containing the component and routing information.
<b>DWG/DXF</b>	CAD Drawing files.
<b>SLDDRW</b>	SOLIDWORKS Drawing Document.

 The PCF can be directly imported into pipe stress analysis software like AutoPIPE, CAESER II or ROHR 2. By default, these documents are located in:  
 C:\ProgramData\SolidPlant Projects\Project 01\Isometric Drawing.

SolidPlant 3D automatically will display the Isometric Drawing in **SLDDRW** document.

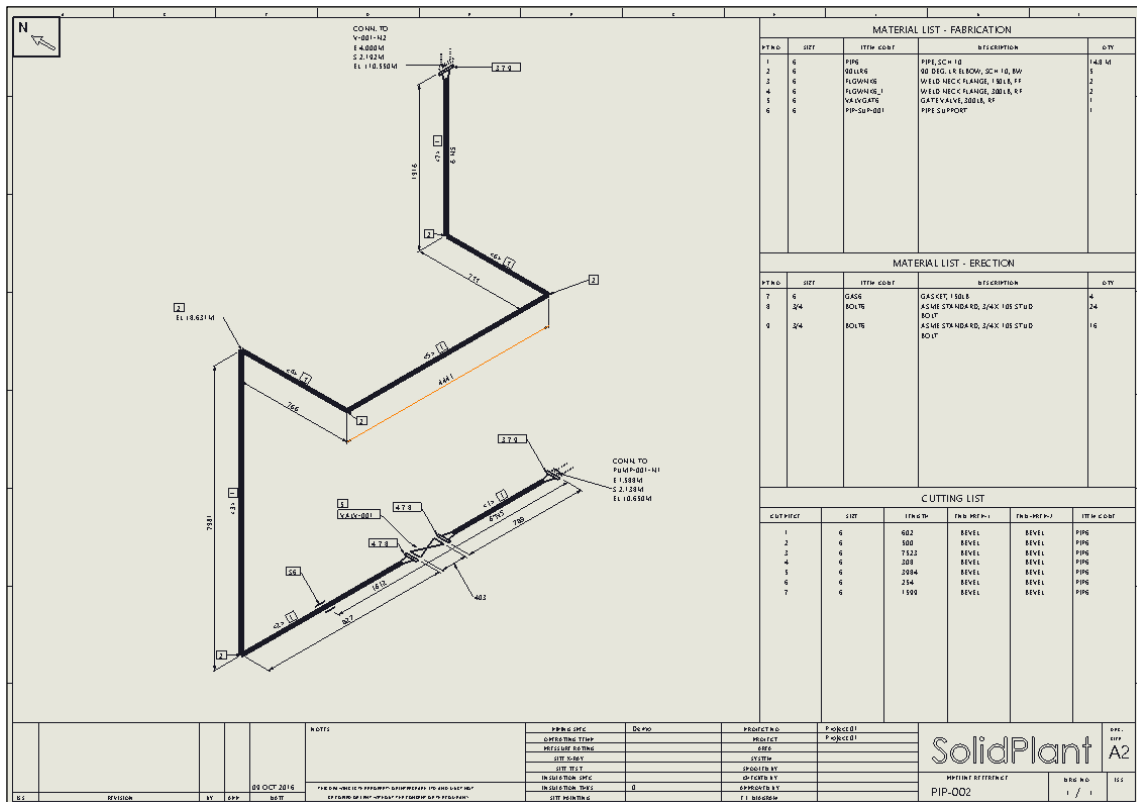

3. Close the SOLIDWORKS drawing of the piping isometric.

These documents will be listed into the **Document List** node tree on the **SolidPlant Project Manager** pane.

4. Click **Refresh**  if not displayed.





The user can access the files directly by right-click on the document in the **Document List** node tree and select **Open Component** from the shortcut menu.

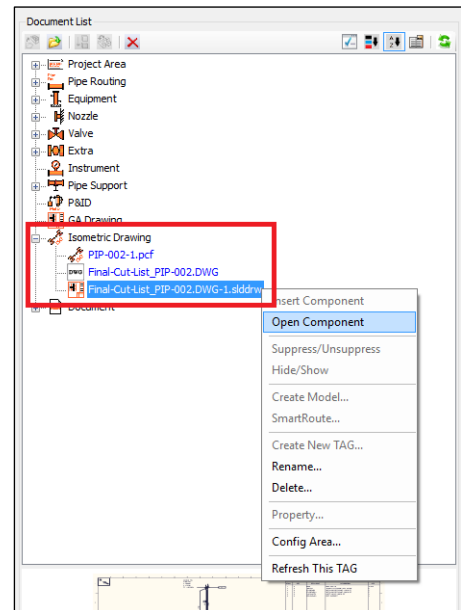

5. Save on **Standard** toolbar.

**New Drawing** command

1. Click **Drawing** Tab > **New Drawing**.

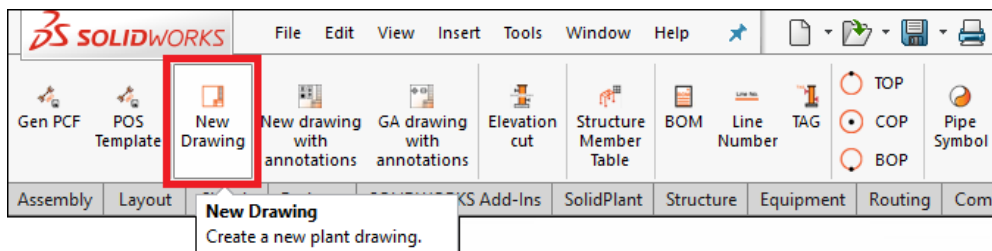

2. Drag and drop the right view of the plant from **View Palette** task pane.

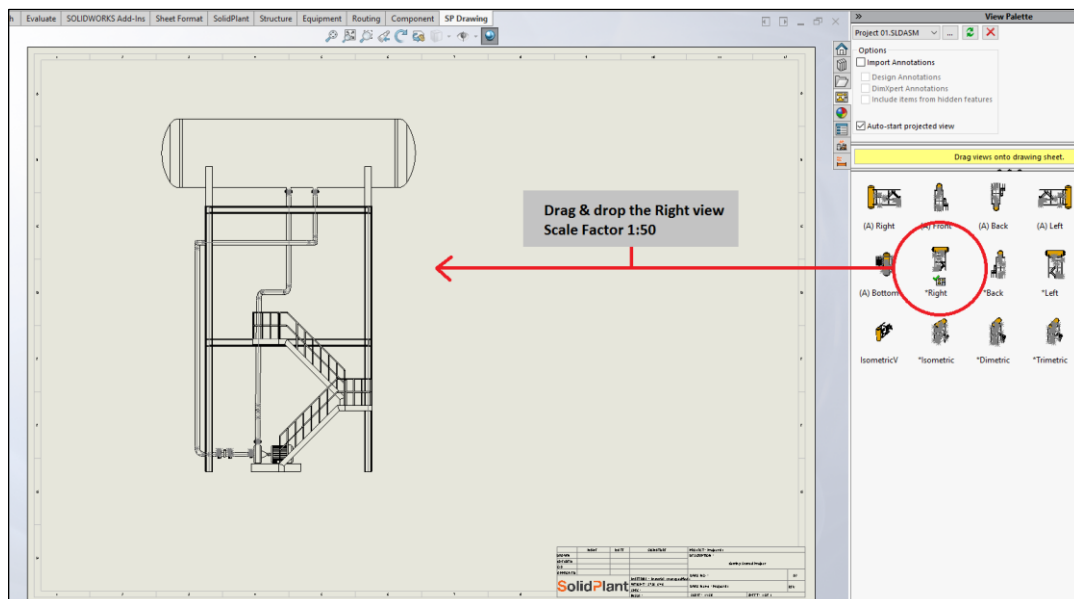

3. Click on any pipe section.
4. Click **Drawing Tab > Line Number** command.

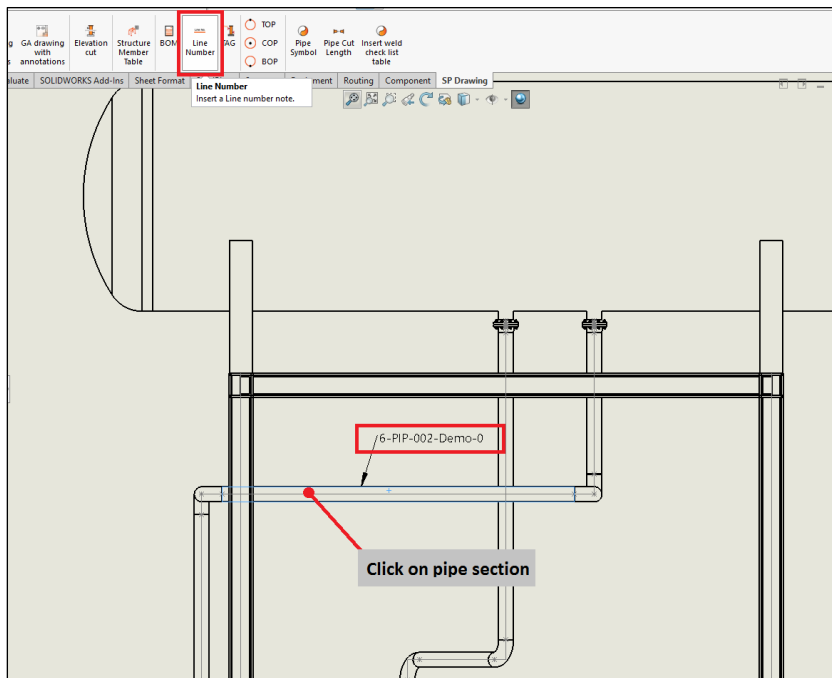

An annotation will be displayed on the pipe section.

5. Click on any pipe section.
6. Click on **Drawing Tab > COP**  .  
The dimension annotation will be displayed between the center of the pipe and the ground level.

- **TOP:** Top Of Pipe.
- **COP:** Center Of Pipe.
- **BOP:** Bottom Of Pipe.

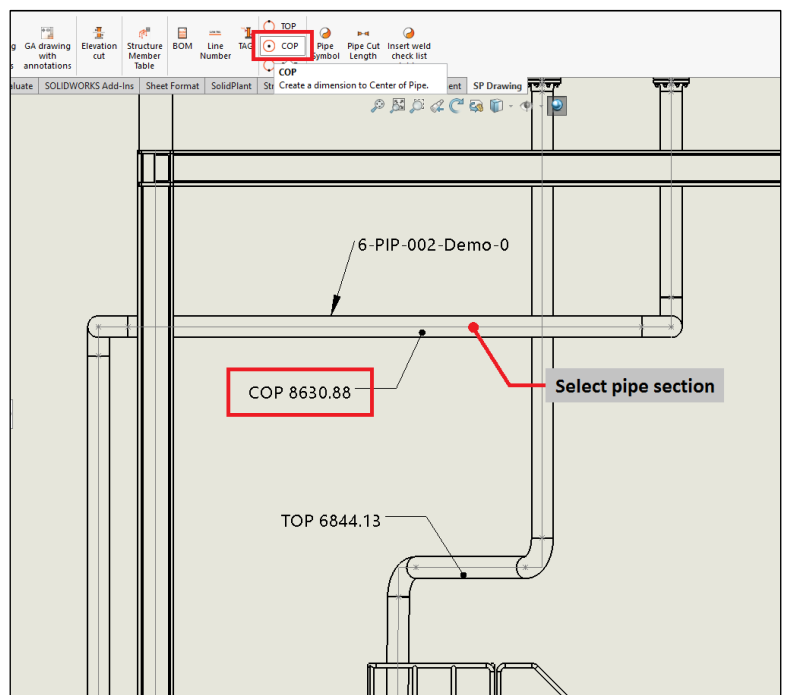

## BOM command

1. Select the project view from the drawing.
2. Click **Drawing Tab > BOM.**

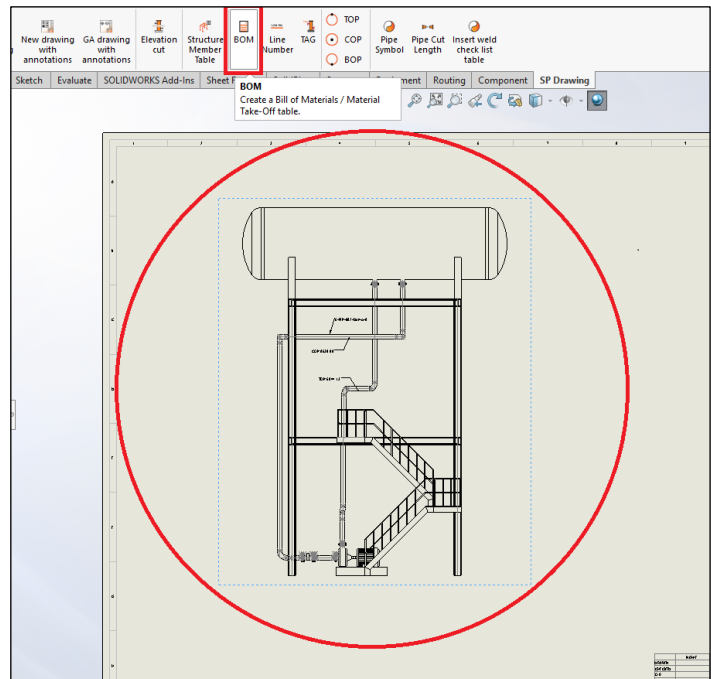

The bill of materials is displayed.

3. Click **To Excel** button to export to an **.xls** file.

AssemblyInfo : C:\ProgramData\SolidPlant Projects\Project 01\Drawing\Project 01.SLDASM

Equipment  
Piping

PUMP-001  
V-001  
PIP-001  
PIP-002

NOZZLE  
PIPE  
BOLT  
ELBOW  
GASKET  
FLANGE  
VALVE  
SUPPORT

Sorted by: [Dropdown] [Add Column] [Delete]

No.	Name	Description	Spec	Size	Quantities
Run #	ITEM_CODE	DESCRIPTION	SPEC	MAIN_SIZE	Quantity
<b>PUMP-001</b>					
1	NOZ6	NON STANDARD...	Demo	6	2
2	NOZ6	NON STANDARD...	Demo	6	2
<b>PIP-001</b>					
3	90LLR6	90 DEG. LR ELB...	Demo	6	4
4	BOLT6	ASME STANDAR...	Demo	6	16
5	FLGWNK6	WELD NECK FLA...	Demo	6	2
6	GAS6	GASKET, 150LB	Demo	6	2
7	PIP6	PIPE, SCH 10	Demo	6	10852 mm
Joint BW-6 10					
Washer Size = 6 32					
Nut Size = 6 32					
<b>PIP-002</b>					
8	PIP-SUP-001	PIPE SUPPORT	Undefined	6	1
9	90LLR6	90 DEG. LR ELB...	Demo	6	5
10	BOLT6	ASME STANDAR...	Demo	6	24
11	BOLT6	ASME STANDAR...	Demo	6	16
12	FLGWNK6	WELD NECK FLA...	Demo	6	2
13	FLGWNK6	WELD NECK FLA...	Demo	6	2
14	GAS6	GASKET, 150LB	Demo	6	4
15	VALVGAT6	GATE VALVE, 300...	Demo	6	1
16	PIP6	PIPE, SCH 10	Demo	6	14771 mm
Joint BW-6 14					
Washer Size = 6 80					
Nut Size = 6 80					

Show Washer  Show Nut  Pipe Cut-List Only  Select All

**To Excel** Close

Click on "To Excel"



The bill of materials is exported to an .xls file and it is automatically opened.

No.	Name	Description	Spec	Size	Quantities
PUMP-001					
1	NOZ6	NON STANDARD 150LB FLAT FACE NOZZLE	Demo	6	2
V-001					
2	NOZ6	NON STANDARD 150LB FLAT FACE NOZZLE	Demo	6	2
PIP-001					
3	90LLR6	90 DEG. LR ELBOW, SCH 10, BW	Demo	6	4
4	BOLT6	ASME STANDARD, 3/4 X 105 STUD BOLT	Demo	6	16
5	FLGWNK6	WELD NECK FLANGE, 150LB, FF	Demo	6	2
6	GAS6	GASKET, 150LB	Demo	6	2
7	PIP6	PIPE, SCH 10	Demo	6	10852 mm
Joint BW-6					
Washer Size = 6					
Nut Size = 6					
PIP-002					
8	PIP-SUP-001	PIPE SUPPORT	Undefined	6	1
9	90LLR6	90 DEG. LR ELBOW, SCH 10, BW	Demo	6	5
10	BOLT6	ASME STANDARD, 3/4 X 125 STUD BOLT	Demo	6	24
11	BOLT6	ASME STANDARD, 3/4 X 105 STUD BOLT	Demo	6	16
12	FLGWNK6	WELD NECK FLANGE, 300LB, RF	Demo	6	2
13	FLGWNK6	WELD NECK FLANGE, 150LB, FF	Demo	6	2
14	GAS6	GASKET, 150LB	Demo	6	4
15	VALVGAT6	GATE VALVE, 300LB, RF	Demo	6	1
16	PIP6	PIPE, SCH 10	Demo	6	14771 mm
Joint BW-6					
Washer Size = 6					
Nut Size = 6					

4. Close the .xls file.

5. Click **Close** to place the bill of materials into the drawing.

AssemblyInfo : C:\ProgramData\SolidPlant Projects\Project 01\Drawing\Project 01.SLDASM

Equipment  
 Piping

PUMP-001  
 V-001  
 PIP-001  
 PIP-002

NOZZLE  
 PIPE  
 BOLT  
 ELBOW  
 GASKET  
 FLANGE  
 VALVE  
 SUPPORT

No.	Name	Description	Spec	Size	Quantities
Run #	ITEM_CODE	DESCRIPTION	SPEC	MAIN_SIZE	Quantity
PUMP-001					
1	NOZ6	NON STANDARD...	Demo	6	2
V-001					
2	NOZ6	NON STANDARD...	Demo	6	2
PIP-001					
3	90LLR6	90 DEG. LR ELB...	Demo	6	4
4	BOLT6	ASME STANDAR...	Demo	6	16
5	FLGWNK6	WELD NECK FLA...	Demo	6	2
6	GAS6	GASKET, 150LB	Demo	6	2
7	PIP6	PIPE, SCH 10	Demo	6	10852 mm
Joint BW-6					
Washer Size = 6					
Nut Size = 6					
PIP-002					
8	PIP-SUP-001	PIPE SUPPORT	Undefined	6	1
9	90LLR6	90 DEG. LR ELB...	Demo	6	5
10	BOLT6	ASME STANDAR...	Demo	6	24
11	BOLT6	ASME STANDAR...	Demo	6	16
12	FLGWNK6	WELD NECK FLA...	Demo	6	2
13	FLGWNK6	WELD NECK FLA...	Demo	6	2
14	GAS6	GASKET, 150LB	Demo	6	4
15	VALVGAT6	GATE VALVE, 300...	Demo	6	1
16	PIP6	PIPE, SCH 10	Demo	6	14771 mm
Joint BW-6					
Washer Size = 6					
Nut Size = 6					

Show Washer  Show Nut  Pipe Cut-List Only  Select All

To Excel **Close**

Click on "Close"





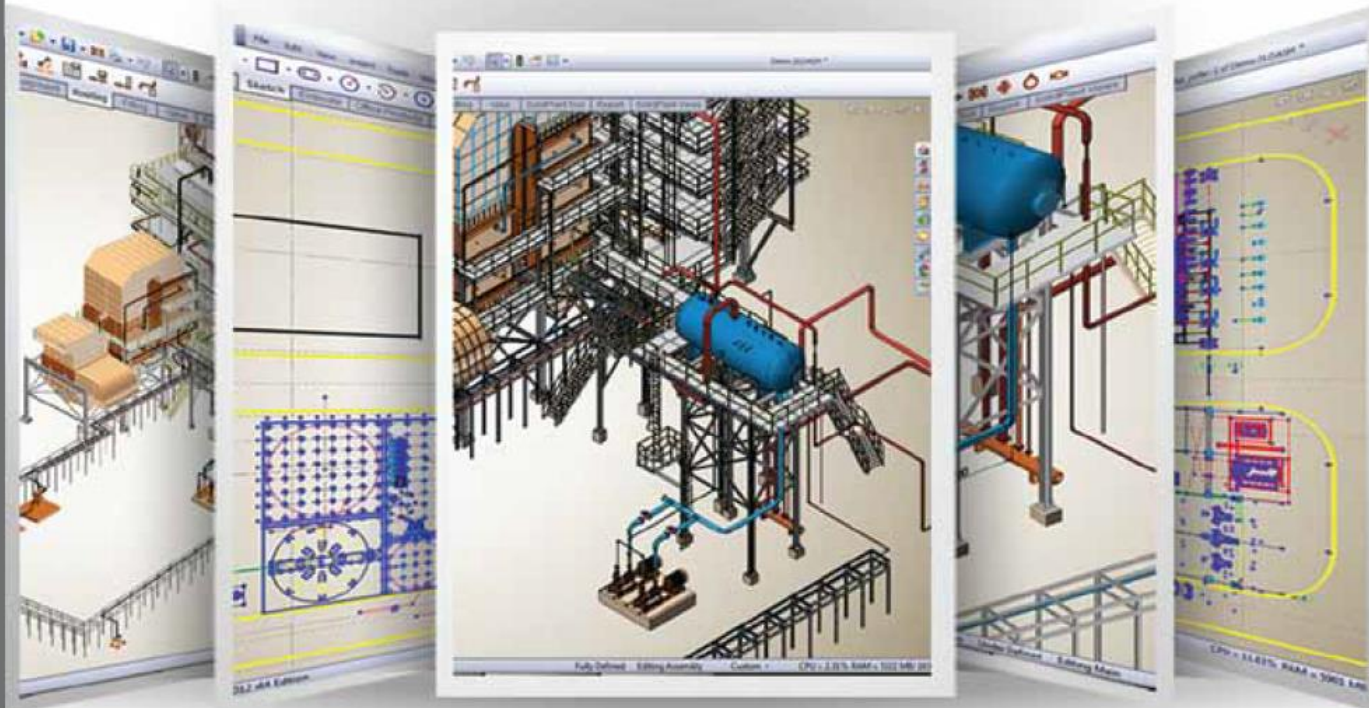

### Finding Answers and Instructions

- Video tutorials on the web : To view multimedia tutorials about using SolidPlant, go to [www.solidplant3d.com](http://www.solidplant3d.com).
- User guides on the web : To download illustrated PDF files with complete instructions for each applications, go to [www.solidplant3d.com](http://www.solidplant3d.com).
- SolidPlant support : For technical support, go to [www.solidplant3d.com/contact.php](http://www.solidplant3d.com/contact.php).
- Product information : For general product information and updates, go to [www.solidplant3d.com](http://www.solidplant3d.com).

### System requirements :

OS : Microsoft Windows 7 (\*64-bit recommended)  
 Processor : Intel or AMD with SSE2 support  
 Memory : 8 GB minimum  
 Disk Space : 5 GB minimum free hard disk space  
 Video Card : 1 GB Microsoft OpenGL or Direct3D capable  
 (\*SolidWorks Certified cards and drivers recommended)  
 Software : SolidWorks 2015 (64 bit recommended)  
 Microsoft Office 2010 (64 bit recommended)



**SolidPlant**

Singel 540 | 1017 AZ Amsterdam Tel. +31(0)20 89 41 393 Fax. +31(0)20 8941 333